



JBL

PROFESSIONAL

VTX SERIES
SYSTEM SOLUTIONS

VTX A8 | User Manual



GENERAL INFORMATION

VTX A8 - User Manual

Document Number: 1000337283

Version: D - EN

Distribution Date: July 13, 2023

Copyright © 2023 by HARMAN International; all rights reserved

JBL PROFESSIONAL

8500 Balboa Blvd

Northridge, CA 91329

USA

Thank you for purchasing JBL VTX Series products



In more than 75 years of JBL innovations, the VTX Series stands apart as a milestone in the practical application of creative engineering. VTX products herald the next generation in line array loudspeaker systems: a new era in performance, system integration and user friendliness. VTX products draw on multiple JBL patents in driver, waveguide, and suspension technology, as well as custom amplification, DSP, control, and system management designs created in collaboration with HARMAN Professional sister companies.

VTX loudspeakers marry custom transducer design and in-house manufacture, breakthrough technologies, and a comprehensive system approach to deliver a premium experience for all who come into contact with it, from the FOH mixing engineer to the systems engineer, rigger, road crew, warehouse manager, and, of course, the audience. Designed for operators of portable and fixed systems alike, the VTX Series features JBL's legendary sound quality coupled with expert support and advanced tools that enable optimal specification, configuration, and operation of VTX systems in any venue, anywhere in the world. The VTX Series delivers a comprehensive solution: the finest sound quality available, plus efficient and intuitive setup, tuning, networking, and control.

TABLE OF CONTENTS

1 - DOCUMENT REVISION HISTORY	6
2 - DECLARATION OF CONFORMITY	7
3 - SAFETY	8
3.1 Safety Instructions	8
3.2 General Hardware Information	8
3.3 Attachment to Structures	8
3.4 Important Safety Warning	9
3.5 Are You New to Rigging?	9
3.6 Inspection and Maintenance	9
3.7 Symbols	10
4 - SYSTEM COMPONENTS	11
5 - COMPATIBLE ACCESSORIES	12
5.1 VTX A8 AF - Array Frame	12
5.2 VTX A8 AF EB - Array Frame Extension Bar	12
5.3 VTX A8 MF - Mini Frame	12
5.4 VTX A8 SB - Suspension Bar	13
5.5 VTX A8 VT - Vertical Transporter	13
5.6 VTX A8 VT CVR - Soft Cover	13
5.7 VTX A8 BP - Base Plate	13
5.8 VTX RC500 - Rotating Clamp	14
5.9 VTX Delta - Delta Plate	14
6 - SOFTWARE	15
6.1 Line Array Calculator 3™	15
6.2 Array Link™	15
6.3 Performance Manager™	15
7 - INTRODUCTION	16
7.1 VTX A8	16
7.2 VTX B18	17
8 - CONNECTIONS	18
8.1 A8 Internal Wiring	19
8.2 B18 Internal Wiring	19
9 - SYSTEM AMPLIFICATION & WIRING	20
9.1 Using A8 With Crown I-Tech 4X3500HD	20
9.2 Using A8 With Crown I-Tech HD (2-CH)	21

9.3 Using A8 and B18 With I-Tech 4X3500HD	22
9.4 Using A8 and B28 With I-Tech 4X3500HD	23
9.5 Crown V-Rack	23
10 - VTX A8 PRESET LIBRARY	24
10.1 VTX A8 Preset Modes and Options	24
10.2 VTX B18/B28 Preset Modes and Options	24
11 - SUBWOOFER OPTIONS	25
11.1 SUB / LF Preset Options	25
11.2 Time Alignment	26
12 - CONFIGURATION EXAMPLES	27
12.1 Small A8 System	27
12.2 Medium A8 System	27
12.3 Large A8 System	28
12.4 Large A8 and A12 System	28
13 - FREQUENCY RESPONSE	29
14 - LINE ARRAY CONTROL PANEL	30
14.1 Accessing LACP	30
14.2 Filter 1 - Array Size Compensation	31
14.3 Filter 2 - Atmospheric Absorption Compensation	31
14.4 Filter 3 - HF Throw Distance Compensation	31
14.5 Filters 4 & 5 - User PEQ 1 & 2	31
14.6 Example using LACP	32
15 - TESTING THE VTX A8	33
15.1 Using a DMM (Digital Multi Meter)	33
15.2 Testing Individual components	34
15.3 Using Performance Manager	35
15.4 Performance Manager Readings	35
16 - SPECIFICATIONS	36
17 - ACOUSTIC MEASUREMENTS	37
18 - DIMENSIONS	37
19 - CONTACT INFORMATION	38

1 - DOCUMENT REVISION HISTORY

VERSION	RELEASE DATE	CHANGES
Version A	August 25, 2018	<ul style="list-style-type: none">• Initial VTX A8 User Manual
Version B	January 5, 2019	<ul style="list-style-type: none">• Minor formatting updates• Updated the VTX A8 MF, VTX A8 BP and RC500 specifications
Version C	December 23, 2020	<ul style="list-style-type: none">• Minor formatting updates• Removed the VTX NL824 accessory• Added the VTX B28 subwoofer and removed the VTX G28 and VTX S28 products
Version D	July 13, 2023	<ul style="list-style-type: none">• Updated amplifier minimum mains voltage requirements for driving B28 and A8 cabinets on a single iTech 4X3500HD amplifier• Updated contact information

2 - DECLARATION OF CONFORMITY

BRAND: JBL Professional

FAMILY NAME: VTX A8 loudspeaker and suspension accessories

MODEL NAMES:

- VTX A8
- VTX A8 AF
- VTX A8 AF EB
- VTX A8 MF
- VTX A8 SB
- VTX A8 BP
- VTX RC500
- VTX A8 VT

We, **HARMAN International**, declare under our sole responsibility that the product, to which this declaration relates, is in conformity with the following standards:

STANDARD	DESCRIPTION	TEST AGENCY
2006/42/EC MACHINERY DIRECTIVE	Applies to machinery and lays down essential health and safety requirements ISO12100	Tested at JBL Professional
2014/35/EC LOW VOLTAGE DIRECTIVE	Applies to loudspeaker and lays down essential health and safety requirements. EN60065	Tested at JBL Professional

Frank Lacelle

Compliance Manager - Harman International

3 - SAFETY

3.1 SAFETY INSTRUCTIONS

1. Read these instructions.
2. Keep these instructions.
3. Heed all warnings.
4. Follow all instructions.
5. Do not expose the product to direct rain or sea spray.
6. Clean only with a dry cloth.
7. Do not install near any heat sources such as radiators, heat registers, stoves, or other apparatus that produce heat.
8. Only use attachments/accessories specified by the manufacturer.
9. Use only with a cart, stand, tripod, bracket, or table specified by the manufacturer or sold with the apparatus. When a cart is used, use caution when moving the cart/apparatus combination to avoid injury from tip-over.
10. Refer all servicing to qualified service personnel. Servicing is required when the apparatus has been damaged in any way, such as if liquid has been spilled or objects have fallen into the apparatus, or if the apparatus has been exposed to rain or moisture, does not operate normally, or has been dropped.
11. Contact JBL Professional for advanced servicing issues.
12. **CAUTION - DO NOT PERFORM ANY SERVICING UNLESS YOU ARE QUALIFIED TO DO SO.**
13. Prolonged exposure to excessive SPL can cause hearing damage. The loudspeaker is easily capable of generating sound pressure levels (SPL) sufficient to cause permanent hearing damage to performers, production crew, and audience members. Caution should be taken to avoid prolonged exposure to SPL in excess of 90 dB.
14. Read the System Rigging Manual before installation and use of the product.

3.2 GENERAL HARDWARE INFORMATION

Any hardware used in an overhead suspension application must be load rated for the intended use. Generally, this type of hardware is available from rigging supply houses, industrial supply catalogs, and specialized rigging distributors. Local hardware stores do not usually stock these products. Compliant hardware will be referenced with a working load limit (WLL) and a traceability code.

3.3 ATTACHMENT TO STRUCTURES

A licensed Professional Engineer must approve the placement and method of attachment to the structure prior to the installation of any overhead object. The following performance standards should be provided to the Professional Engineer for design purposes: Uniform Building Code as applicable, Municipal Building Code as applicable, and Seismic Code as applicable. The installation of the hardware and method of attachment must be carried out in the manner specified by the Professional Engineer. Improper installation may result in damage, injury, or death.

3.4 IMPORTANT SAFETY WARNING

The information in this section has been assembled from recognized engineering data and is intended for informational purposes only. None of the information in this section should be used without first obtaining competent advice with respect to applicability to a given circumstance. None of the information presented herein is intended as a representation or warranty on the part of JBL. Anyone making use of this information assumes all liability arising from such use.

All information presented herein is based upon materials and practices common to North America and may not directly apply to other countries because of differing material dimensions, specifications, and/or local regulations. Users in other countries should consult with appropriate engineering and regulatory authorities for specific guidelines.

Correct use of all included hardware is required for secure system suspension. Careful calculations should always be performed to ensure that all components are used within their working load limits before the array is suspended. Never exceed the maximum recommended load ratings.

Before suspending any speaker system, always inspect all components (enclosure, rigging frames, pins, eyebolts, track fittings, etc.) for cracks, deformations, corrosion, or missing/loose/damaged parts that could reduce strength and safety of the array. Do not suspend the speaker until the proper corrective action has been taken. Use only load-rated hardware when suspending JBL suspendable loudspeaker models.

3.5 ARE YOU NEW TO RIGGING?

If you are new to rigging, you should:

- Know the rules for safe rigging.
- Attend a safe rigging seminar.
- Meet and establish a relationship with a licensed mechanical or structural engineer. Get in the habit of asking them questions instead of assuming their answers. Learn from what they tell you.
- Research and understand the codes, practices and requirements of the venues where you intend to operate your sound system.

3.6 INSPECTION AND MAINTENANCE

Suspension systems are comprised of mechanical devices and, as such, require regular inspection and routine maintenance to ensure proper functionality. Before suspending or pole mounting any speaker system, always inspect all components (enclosure, suspension frames or brackets, pins, eyebolts, etc.) for cracks, deformations, corrosion, or missing/loose/damaged parts that could reduce strength and safety of the array. Do not suspend or pole mount a speaker until the proper corrective action has been taken.

Installed systems should be inspected at least once a year. The inspection must include a visual survey of all corners and load-bearing surfaces for signs of cracking, water damage, delamination, or any other condition that may decrease the strength of the loudspeaker enclosure.

Accessory suspension hardware provided with or for VTX systems must be inspected for fatigue at least once a year or as required by local ordinance. The inspection must include a visual survey of the material for signs of corrosion, bending, or any other condition that may decrease the strength of the fastener. Additionally, any eyebolts must be checked for possible spin-out of the enclosure.

For all other hardware and fittings, refer to the hardware manufacturer's inspection and maintenance guidelines for process.

JBL is not responsible for the application of its products for any purpose or the misuse of this information for any purpose. Furthermore, JBL is not responsible for the abuse of its products caused by avoiding compliance with inspection and maintenance procedures or any other abuse.

Prior to suspending the system, an expert, trained and experienced in suspending speaker systems, should inspect all parts and components.

3.7 SYMBOLS

The following symbols are used in this document:



CAUTION: This symbol gives notice of a potential risk of harm to the individual or the equipment. Instruction marked with this symbol must be strictly followed.



TIP: This symbol gives notice of helpful, relevant information about the topic.



INSTRUCTIONS: This symbol gives notice of instructions that must be followed for proper installation and use of the product.



TOOLS REQUIRED: This symbol gives notice of tools that must be used for proper installation and use of the product.

4 - SYSTEM COMPONENTS

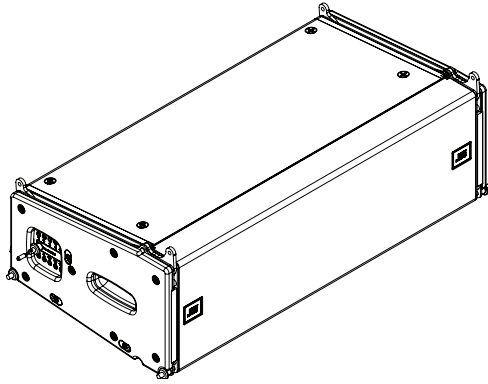

VTX A8

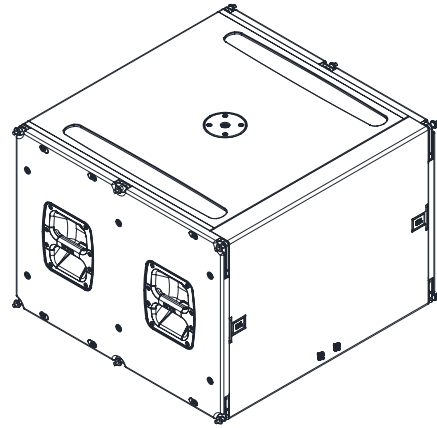

VTX B18

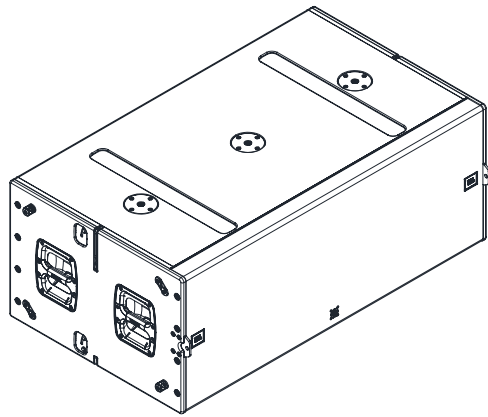

VTX B28

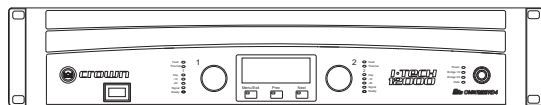
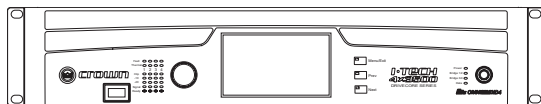

Crown I-Tech HD Amplifiers

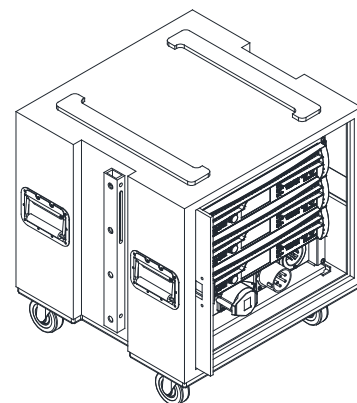

Crown Audio V-Rack

5 - COMPATIBLE ACCESSORIES

All listed accessories are compatible with the VTX A8 and, in some cases, the VTX B18. For subwoofer specific accessories refer to the **B18 User Manual** and **Rigging Manual** found at www.jblpro.com.

5.1 VTX A8 AF - ARRAY FRAME

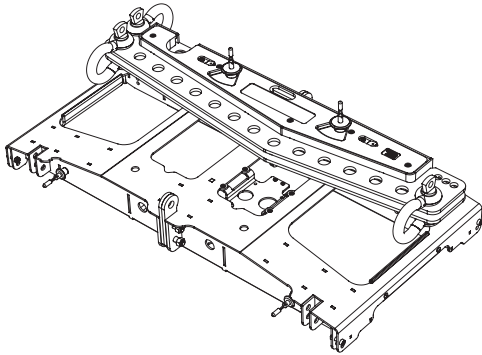

- Compatible with VTX A8 and VTX B18
- Maximum Limit: (24) VTX A8 / (13) VTX B18
- 0.5 degree pick-point resolution
- Built-in storage position for extension bar
- Includes (1) VTX A8 AF EB extension bar
- Support for third-party laser inclinometers
- Compatible shackle size: 5/8 in

5.2 VTX A8 AFEB - ARRAY FRAME EXTENSION BAR

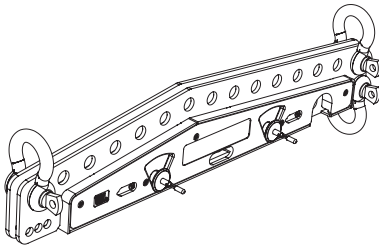

- Extension Bar for use with VTX A8 AF
- Single, front-to-back or side-by-side pick point options
- Includes (3) shackles and mounting brackets
- Compatible shackle size: 5/8 in

5.3 VTX A8 MF - MINI FRAME

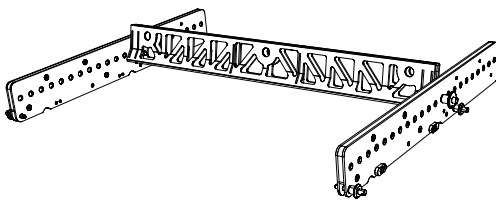

- Compatible with VTX A8 and VTX B18
- Maximum Limit: (10) VTX A8 / (4) VTX B18
- Single-point and side-by-side pick-point options
- Three-part collapsible design
- Compatible shackle size: 1/2 in

5.4 VTX A8 SB - SUSPENSION BAR

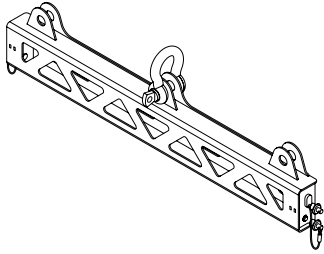

- Compatible with VTX A8 and VTX B18
- Maximum Limit: (24) VTX A8 / (16) VTX B18
- Used for pull-back applications
- Shackle Size: 5/8 in

5.5 VTX A8 VT - VERTICAL TRANSPORTER

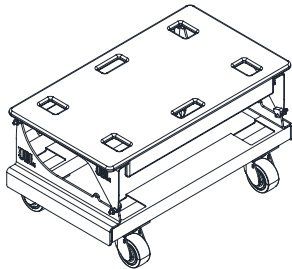

- Vertical transport cart for (4) VTX A8 enclosures
- Truck-friendly dimensions
- Includes a hard top (VT-TOP)
- Built-in stacking features for easy storage
- Heavy-duty casters

5.6 VTX A8 VT CVR - SOFT COVER

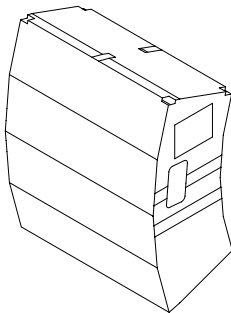

- Heavy-duty soft cover for VTX A8 enclosures
- Covers four VTX A8 enclosures on a VTX A8 VT
- Includes input panel flaps for testing purposes
- Clear see-through pocket for shipping labels
- Handle cutouts for easy transportation
- Folds and stores in the VTX A8 VT

5.7 VTX A8 BP - BASE PLATE

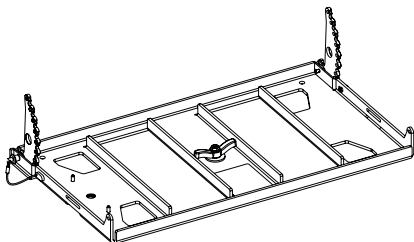

- Used for ground stacking VTX A8
- Maximum Limit: (8) VTX A8 cabinets
- Connects VTX A8 cabinets to subwoofers
- Universal M20 attachment method
- Tilt range: -15 degrees to +5 degrees

5.8 VTX RC500 - ROTATING CLAMP

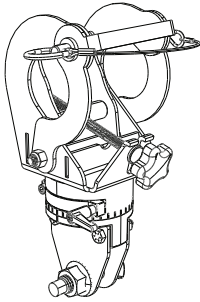

- Universal truss/pipe clamp adapter
- Working Load Limit: 500 kg (1,100 lbs)
- Adjustable clamping mechanism
- Pipe range: 1 – 2.0 in
- Includes bearing for smooth 360-degree rotation
- 10-degree rotation marks for horizontal array aiming

5.9 VTX DELTA - DELTA PLATE

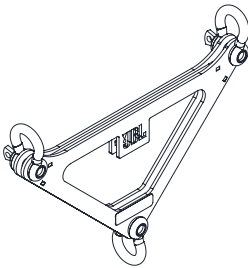

- Universal delta plate accessory for VTX systems
- Allows for +/- 10 degree horizontal adjustments
- Includes three 5/8 in shackles
- Working Load Limit: 2,177 kg (4,800 lbs)



TIP: For subwoofer-specific accessories, refer to the subwoofer user and rigging manuals found at www.JBLpro.com.



CAUTION: Always use components and accessories specified and approved by JBL Professional. When a cart is used, use caution when moving the cart to avoid injury from tip-over.

6 - SOFTWARE

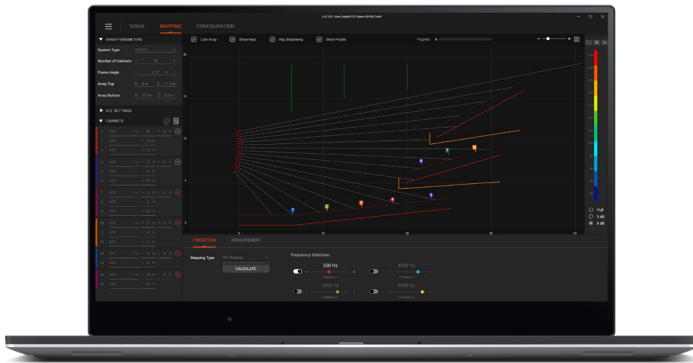

6.1 LINE ARRAY CALCULATOR 3™

LAC is simulation software for designing and predicting VTX Series systems. LAC predicts the acoustical performance of line array systems, as well as flown and ground-stacked subwoofer arrays. Subwoofer delay values can be generated for electronic delay steering (EDS) using the built-in coverage calculator. LAC also performs mechanical validation of rigging hardware, calculates weight limits, and generates safety warnings.

www.jblpro.com/lac3

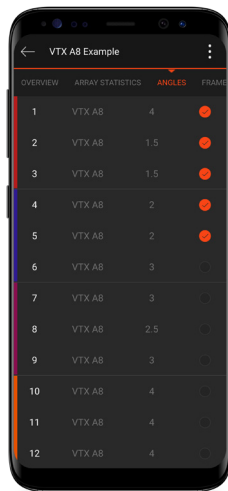

6.2 ARRAY LINK™

Array Link is a mobile companion app that works in conjunction with LAC software to assist in deployment of VTX Series systems. Array Link uses a QR code system to transfer all mechanical array information from the main LAC application to a mobile phone. All relevant rigging and mechanical options are presented in an easy-to-understand layout. The application is compatible with iOS® and Android™ and can be obtained from their respective app stores.

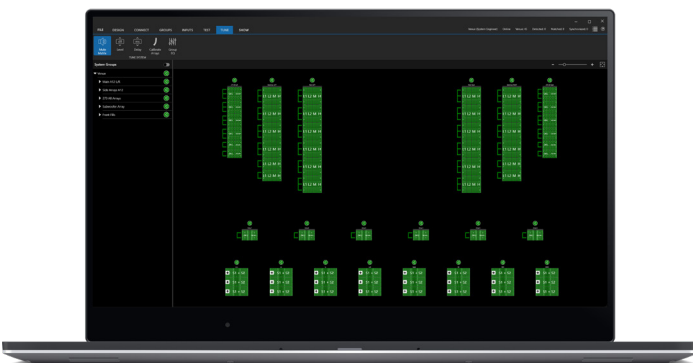

6.3 PERFORMANCE MANAGER™

Performance Manager is a configuration and control application for networked audio systems. Performance Manager's user interface guides system designers through the complete system design, configuration, and control processes. A dedicated show mode provides all monitoring and control functions needed to deliver a complete picture of the system's performance in real time.

www.jblpro.com/performancemanager

7 - INTRODUCTION

7.1 VTX A8

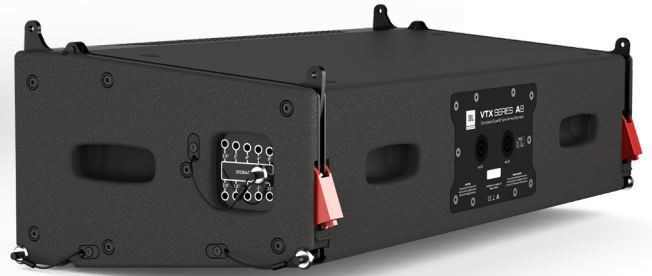

The VTX A8 is a next-generation line array element that delivers JBL Professional's flagship VTX A Series technology in a compact solution for small to mid-size rental and installed applications. The VTX A8 was designed to solve the diverse sound reinforcement needs of production companies, rental houses, theaters, houses of worship, as well as production applications requiring front fills, side arrays or other auxiliary support for larger-scale VTX systems. Proprietary woofers and our latest-generation high-frequency transducer and waveguide technology, provide unmatched performance, efficiency, and a consistent 110-degrees of horizontal coverage. The A8 combines two 8-inch woofers, four 3.5-inch midrange drivers and two 2-inch high frequency drivers in a single low-profile cabinet. Proprietary double-flared low frequency ports, precisely calculated for greater low frequency performance extend the usable operating range down to 49 Hz. The VTX A8 shares the VTX A Series' patented rigging mechanism and suspension system for streamlined deployment, while a comprehensive suite of accessories open up a world of configuration options.

INSIDE THE INNOVATIONS

For VTX A8, transducers were engineered from the ground up by JBL to match the physical characteristics of its compact enclosure. Custom-designed low and mid frequency sections along with flagship VTX A-Series two-inch compression drivers deliver higher output, lower distortion and greater low frequency extension. Physical design refinements integrate more drivers in a smaller, lighter cabinet, for maximum output in a dramatically reduced footprint. It all adds up to big-system JBL sound in a flexible, compact line array system.

3-WAY, 2-CHANNEL DESIGN

The VTX A8 features a three-way design, but utilizes a passive network to drive both the MF and HF sections with a single amplifier channel. Reducing system amplifier count translates to simpler configuration, less total weight and truck space, and lower overall costs.

INNOVATIVE RIGGING

The VTX A8 rigging is identical to the A12 rigging, for quick, easy deployment of integrated systems. The rigging features an auto-locking mechanism, which allows the selection of angles while components are on the ground; once the system is suspended, the mechanism automatically locks cabinet angles in designated positions. Set angles simply by pulling and placing a pin—it's that easy.

ACCESSORIES

Multiple accessory options provide flexibility in the VTX A8's mounting, integration and installation capabilities. Highlights include a Base Plate that mounts the A8 on top of ground-stacked subwoofers such as the new B18. The truss clamp and mini frame enable the A8 to be mounted on a truss, making it ideal for trade shows or small productions.

7.2 VTX B18



The VTX B18 is JBL Professional's single 18-inch subwoofer, designed to complement VTX full-range sound reinforcement systems. The VTX B18 features JBL's 2288H 18-inch woofer, engineered for improved linearity, increased sensitivity and extra-long excursion. The 2288H is based on JBL's Differential Drive, dual voice coil, dual gap technology, which delivers better heat dissipation, lower power compression, and wider dynamic range than conventional single-coil designs. The B18 incorporates a patented Slip Stream™ double-flared exponential low frequency port design to improve airflow and reduce audible turbulence, even at maximum excursion. The B18 shares the industrial design of the VTX A-Series products and has the same width and suspension hardware as the VTX A8, allowing the two products to be used together in a variety of flown or ground stacked configurations. B18 subwoofers can be deployed in omnidirectional or cardioid arrays, ground stacked, or in suspended configurations of up to 16 enclosures.

TRANSDUCER DESIGN

The VTX B18 features a JBL 2288H 18-inch high-performance woofer engineered from the ground up to deliver transparent, linear bass response down to 28 Hz. The 18-inch driver leverages a patented fourth-generation Differential Drive technology to deliver maximum sensitivity and power handling in a light, compact design.

VTX A8 COMPATIBILITY

The B18 rigging system is compatible with the VTX A8 rigging system, allowing B18 subwoofers to be suspended above an A8 array. The VTX B18 rigging system allows for omnidirectional or cardioid configurations in small and large-scale flown or ground-stacked arrays. All VTX A8 suspension accessories are compatible and arrays of up to 16 enclosures can be created.

CONTROLLABLE COVERAGE

The B18 makes it simple to form omnidirectional or cardioid arrays. Speaker connectors are available on both front and rear panels, streamlining cable management in either configuration. A switch on the rear input panel allows for selecting between channel 1 or 2 of the NL4 cable, minimizing cable requirements.

VTX BUILD QUALITY

The VTX B18 adopts the VTX A-Series' signature full-face grill design, which minimizes exposed components and protects the loudspeaker from extreme conditions. The enclosed grill helps the system achieve a higher Ingress Protection (IP55) rating.

8 - CONNECTIONS

The JBL VTX A8 is equipped with two Neutrik NL4 speakON connectors. The NL4 connectors are wired in parallel and can be used as the system input or as a through connection for daisy-chaining multiple cabinets together. The NL4 connectors are installed upside down so that the locking pin position can be seen from under the array.

NL4 Connectors : IN/OUT

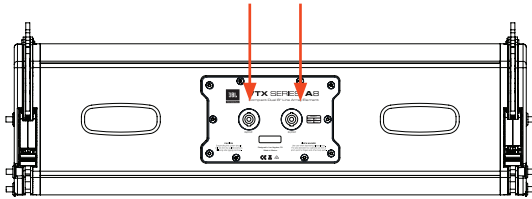

The VTX B18 is equipped with four Neutrik NL4 speakON connectors, two at the rear for the cabinet and two at the front grill. All four NL4 connectors are wired in parallel and can be used interchangeably. The NL4 connectors at the front of the B18 are typically used when the B18s are setup in a cardioid configuration, where some of the enclosures are pointed backwards. All NL4 connectors are installed upside down so that the NL4 locking pin position can be seen from under the array.

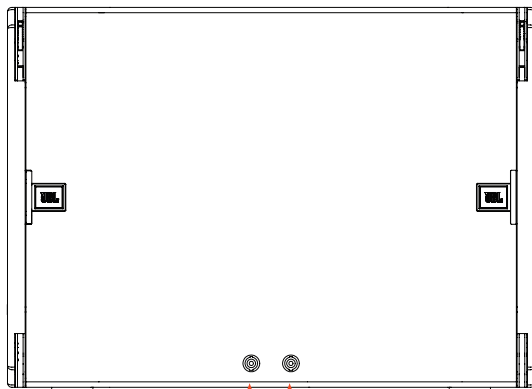

Front NL4 Connectors : IN/OUT

Rear NL4 Connectors : IN/OUT

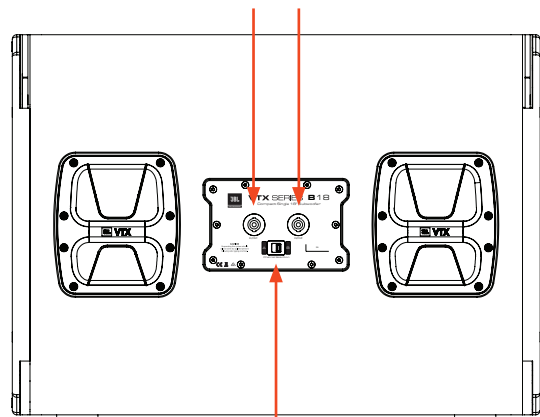

Channel Selection Switch

A channel selection switch is available at the rear of the B18, which selects between Pin 1 and Pin 2 of the NL4 connector. The switch is wired after the NL connectors and affects all connections equally. For more information on the B18, refer to the [VTX B18 User Manual](#).



CAUTION: Always use high-quality insulated speaker cables made by reputable manufacturers. Keep cable length as short as possible with sufficient gauge for the application.

8.1 A8 INTERNAL WIRING

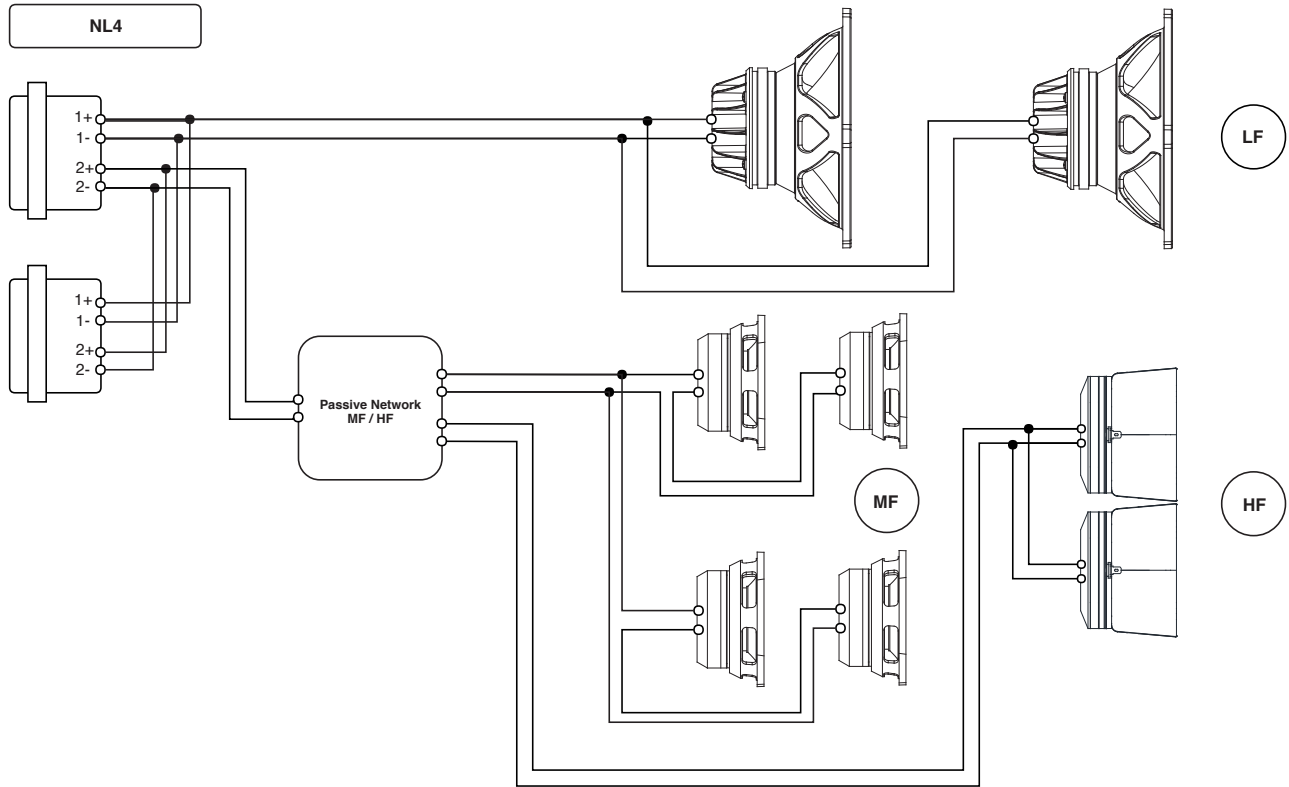

8.2 B18 INTERNAL WIRING

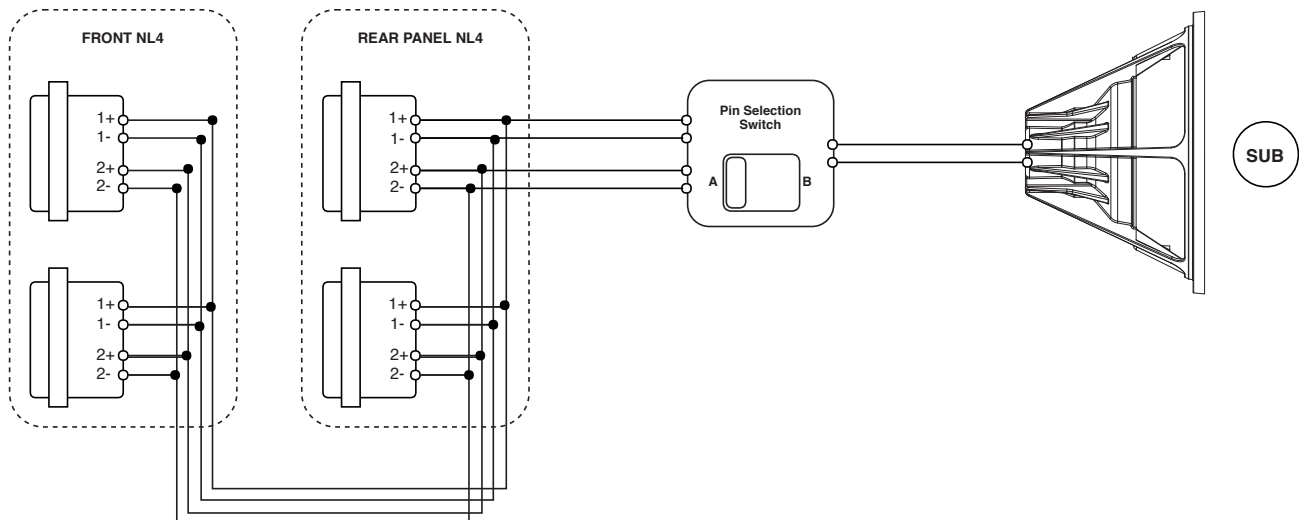

9 - SYSTEM AMPLIFICATION & WIRING

Like all other VTX systems, the VTX A8 and B18 cabinets are powered exclusively by Crown I-Tech HD amplifiers, providing consistency and optimum performance anywhere in the world. All speaker processing is performed using the I-Tech HD's internal processing, which includes the advanced LevelMax™ three-stage limiter suite, ensuring proper, reliable operation under any conditions. LevelMax incorporates excursion control, RMS limiting, and long-term thermal protection for the transducers. The I-Tech HD amplifiers also offer a user-adjustable input section for equalization, time alignment, and electronic delay steering. Standard JBL presets are available for both the Crown I-Tech 4x3500HD and I-Tech 12000HD. The most up-to-date presets are available for download from www.jblpro.com, and bundled in the latest version of Performance Manager control software.

9.1 USING A8 WITH CROWN I-TECH 4X3500HD

When using Crown I-Tech 4x3500HD amplifiers, up to six VTX A8 loudspeakers (three per circuit) can be powered per amplifier. Based on the power demands of the A8, this allows for optimum power-to-transducer ratio without compromising the maximum SPL capabilities of the system. Circuits with two cabinets can be used to create smaller coverage areas in the venue for finer control. The example below illustrates how to connect six VTX A8 cabinets to an I-Tech 4x3500HD amplifier using standard four-contact NL4 cables.

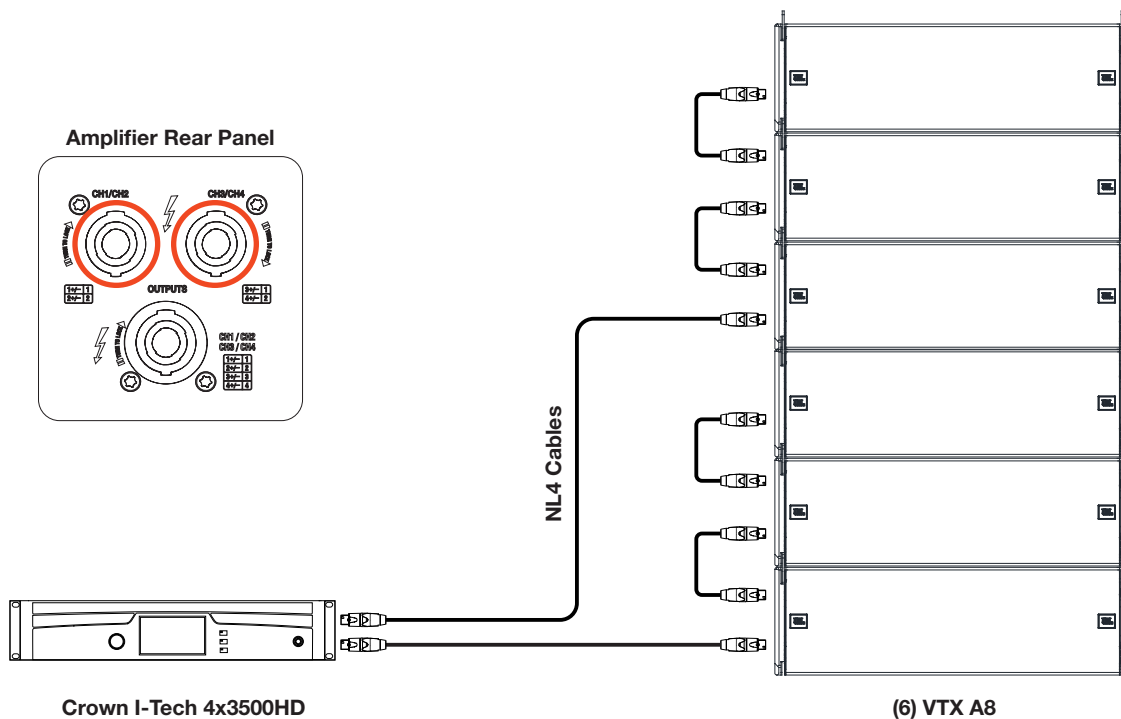

Amplifier Channels	
Channel 1	A8 LF
Channel 2	A8 MF/HF
Channel 3	A8 LF
Channel 4	A8 MF/HF

Standard NL8 cables can be used to connect VTX A8 cabinets to a Crown I-Tech 4x3500HD amplifier using an NL8-to-two-NL4 breakout cable. Using this breakout cable, up to six VTX A8 cabinets can be connected to a four-channel amplifier using a single NL8 cable, saving cables and simplifying wiring.

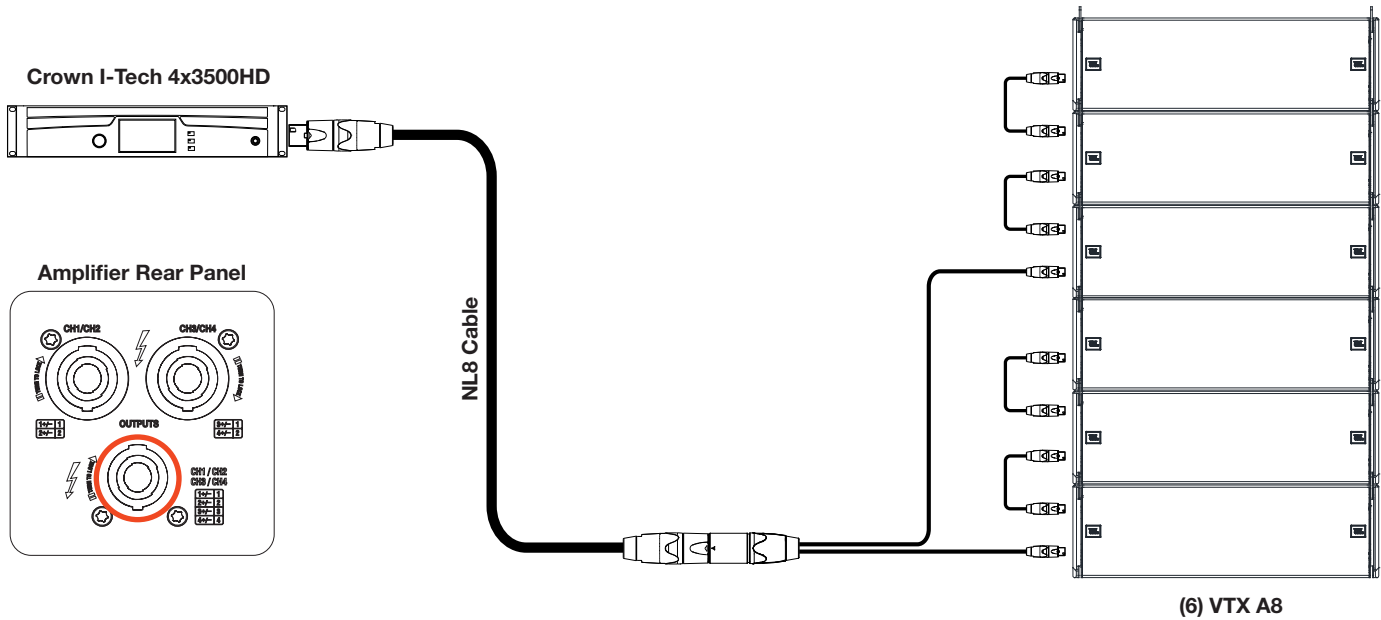

9.2 USING A8 WITH CROWN I-TECH HD (2-CH)

When using Crown I-Tech HD amplifiers (two-channel), up to three VTX A8 loudspeakers can be powered per amplifier. One channel is used for powering the low frequency section and another for the mid and high frequency sections. Based on the power demands of the A8, this allows for optimum power-to-transducer ratio without compromising the system's maximum SPL capabilities. Circuits with two cabinets can be used to create smaller coverage areas in the venue for finer control. The example below illustrates how to connect three VTX A8 cabinets to a two-channel I-Tech HD amplifier using a standard four-contact NL4 cable.

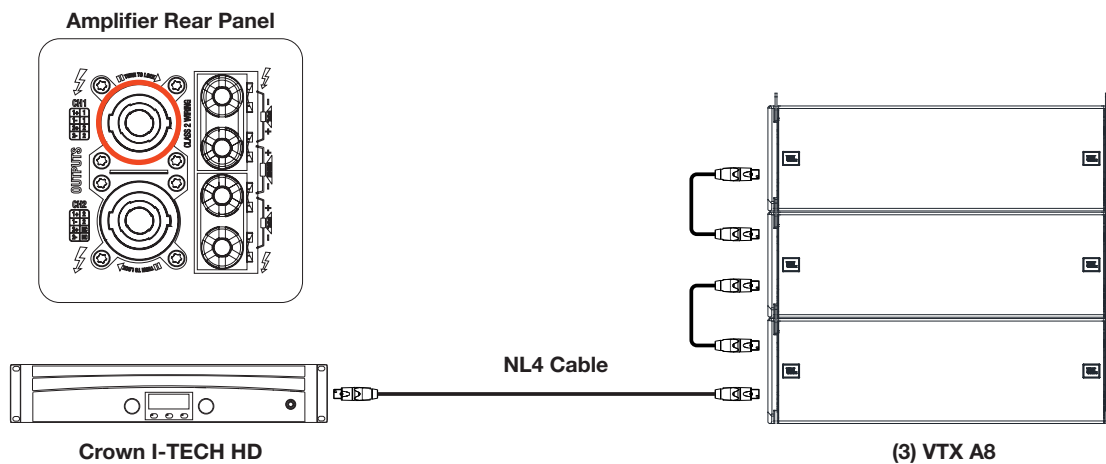

Amplifier Channels	
Channel 1	A8 LF
Channel 2	A8 MF/HF

9.3 USING A8 AND B18 WITH I-TECH 4X3500HD

A8 and B18 products can be combined on a single I-Tech 4x3500HD amplifier. In this case, the amplifier has enough resources to power four B18 subwoofers and up to three A8 cabinets without compromising SPL or the long-term thermal capabilities of the amplifier.

Amplifier Channels

- Channel 1 B18 1 & 2
- Channel 2 B18 3 & 4
- Channel 3 A8 LF
- Channel 4 A8 MHF

Amplifier Rear Panel

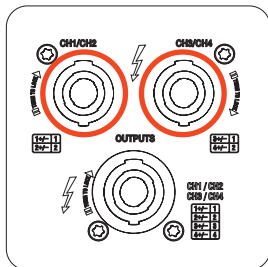

Crown I-Tech 4x3500HD

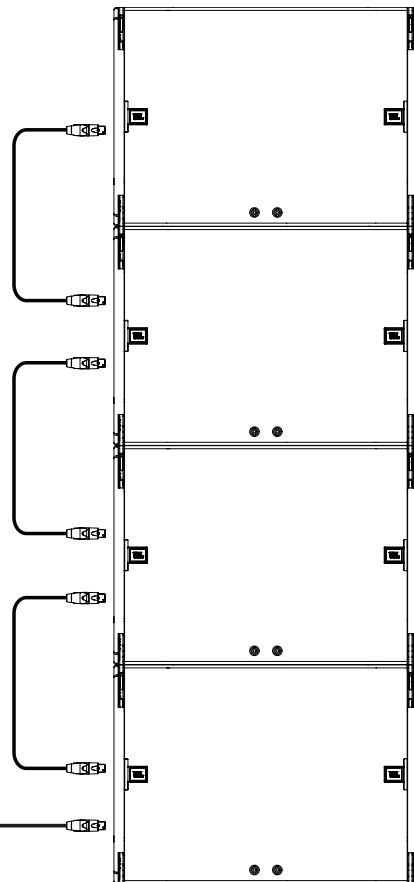

(4) VTX B18



(3) VTX A8

Channel Selection Switch



CAUTION: Driving more than four B18 subwoofers from a single iTech 4X3500HD is not recommended. The mains voltage must be 208V or above when powering B18 and A8 cabinets from a single amplifier.

9.4 USING A8 AND B28 WITH I-TECH 4X3500HD

When using Crown I-Tech 4x3500HD amplifiers, up to two VTX B28 subwoofers can be powered per amplifier and the remaining channels can be used to power a JBL full-range speaker, such as the VTX A8. The example below illustrates how to connect two VTX B28 cabinets and three VTX A8 to a four-channel I-Tech HD amplifier. A cable breaking the NL4 connector out to two NL2 connectors can be used to drive one B28 each from amplifier channels 1 and 2. A four-conductor NL4 cable is employed in this arrangement, reducing cabling requirements. Amplifier channels 3 and 4 remain available for driving a full-range product, such as the VTX A8.

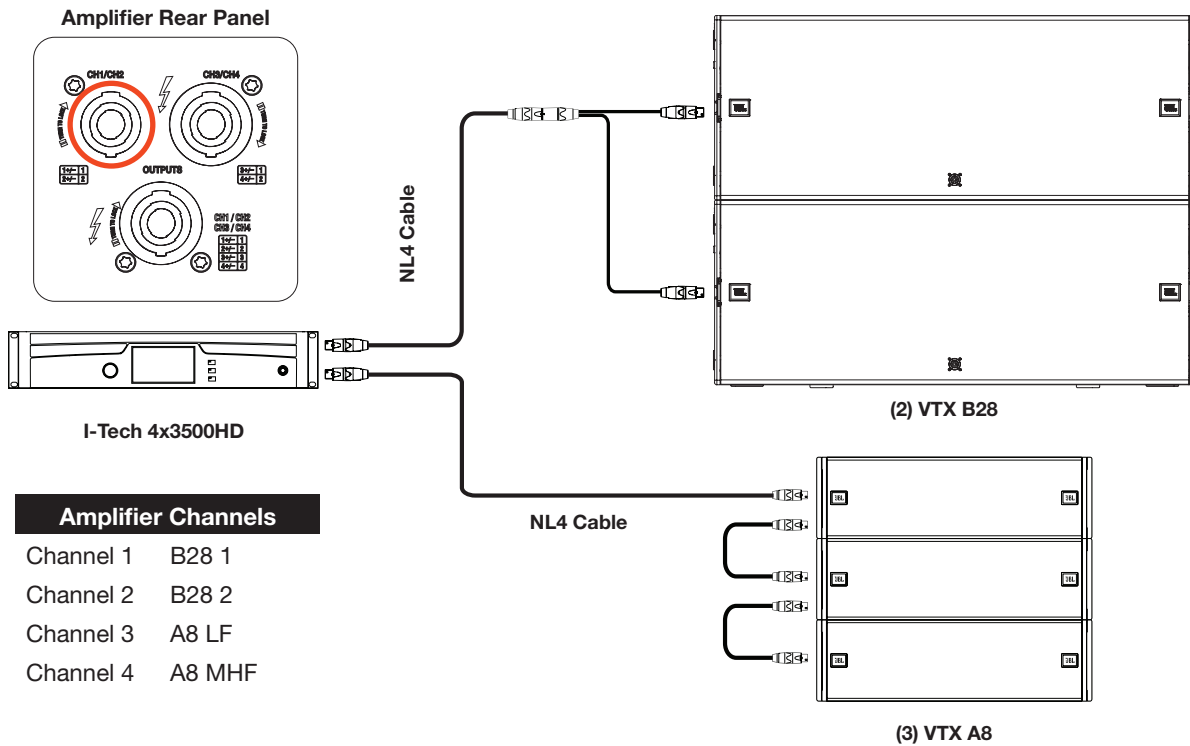

CAUTION: Driving more than two B28 subwoofers from a single iTech 4X3500HD is not recommended. The mains voltage must be 208V or above when powering B28 and A8 cabinets from a single amplifier.

9.5 CROWN V-RACK

VTX Series systems are compatible with the Crown V-Rack 12000HD and Crown V-Rack 4x3500HD touring racks. The number of cabinets supported by each amplifier and the wiring options remain the same as the Crown I-Tech examples illustrated in this document. For more information on Crown V-Rack products, refer to the V-Rack User Manual and documentation.

10 - VTX A8 PRESET LIBRARY

The VTX A8 preset library includes standard array and fill (FL) operating modes, along with full-range and 80 Hz low frequency processing modes. VTX presets are exclusively developed for Crown I-Tech HD amplifiers and come bundled with Performance Manager control software. Audio Architect™ presets are also available and can be downloaded from www.jblpro.com. Below is a detailed description of VTX A8 operating modes and subwoofer processing options. Refer to the Preset Library setup sheets for preset descriptions, memory locations and output channel assignments.

10.1 VTX A8 PRESET MODES AND OPTIONS

Two preset modes and two low frequency processing options are available:

VTX A8 FL: The FL presets (short for FILL) have nominally flat frequency response and are to be used in situations where one or two A8 cabinets are appropriate, such as distributed front fills. With this preset, the acoustical low frequency response of the system extends down to 49 Hz (full range).

VTX A8 FL 80: The FL 80 presets have nominally flat frequency response and are to be used in situations where one or two A8 cabinets are appropriate, such as distributed front fills. With this preset, the acoustical low frequency response of the system is set to 80 Hz and used when subwoofers are available.

VTX A8: This is the standard VTX A8 preset for array use. A high frequency shelving response is applied to offset LF/MF array buildup for nominally-focused arrays (equally spaced impact points over the desired audience coverage area). With this preset, the acoustical low frequency response of the system extends down to 49 Hz (full-range).

VTX A8 80: This is the standard VTX A8 preset for array use with subwoofers. A high frequency shelving response is applied to offset LF/MF array buildup for nominally focused arrays (equally spaced impact points over the desired audience coverage area). With this preset, the acoustical low frequency response of the system is set to 80 Hz. The VTX A8 80 preset will generate the highest A-weighted maximum sound pressure level.

10.2 VTX B18/B28 PRESET MODES AND OPTIONS

VTX BXX 60: The 60 Hz preset mode extends the upper frequency response of the subwoofer to 60 Hz. The 60 Hz preset is normally used when VTX cabinets (like the A8 or A12) are used in full-range mode.

VTX BXX 60 REAR: The 60 Hz rear preset was designed to work in conjunction with the standard 60 Hz preset to drive rear-facing B18 cabinets in cardioid configurations.

VTX BXX 80: The 80 Hz preset mode extends the upper frequency response of the subwoofer to 80 Hz. The 80 Hz preset is normally used when VTX full-range cabinets (like the VTX A8 or A12) are set to 80 Hz.

VTX BXX 80 REAR: The 80 Hz rear preset was designed to be work in conjunction with the standard 80 Hz preset to drive rear-facing B18 cabinets in cardioid configurations.



TIP: The VTX A8 presets provide a well-balanced tonal starting point for a given array size. The Array Size Compensation filter found in the JBL Line Array Control Panel (LACP) can be used to further fine-tune the tonal balance of an array for a given size and shape. Please refer to the LACP section for more information.

11 - SUBWOOFER OPTIONS

VTX A8 presets are designed for a 3:2 minimum cabinet ratio when used with the VTX B18, and a 3:1 ratio when used with dual 18-inch subwoofers like the VTX B28, G28 or VTX S28. The minimum recommended ratios provide sufficient headroom for both the subwoofers and the full-range cabinets to reach MAX SPL (limiters) at the same time, while maintaining a minimum of 10 dB SUB to full-range low frequency contour. Other ratios can be used depending on the desired tonal balance target, MAX SPL and application.

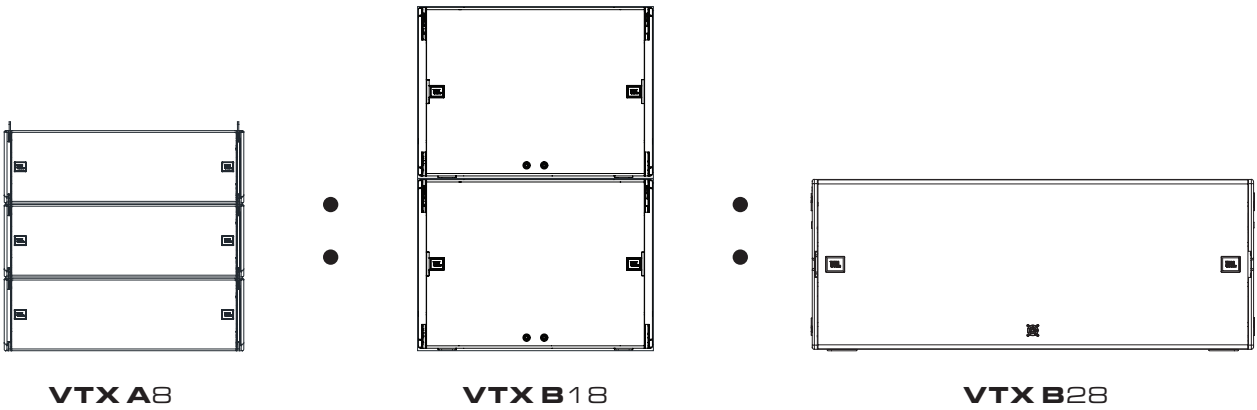

11.1 SUB / LF PRESET OPTIONS

As previously mentioned, there are two LF presets available for the A8 system: one is the VTX A8 (full-range) preset, which extends the frequency response of the system down to 49 Hz; the other is the VTX A8 80 (80 Hz) preset, which extends the frequency response of the system down to 80 Hz. The VTX A8 (full-range) preset is used when the system is operated without subwoofers or when the application calls for extended LF response from the main arrays. The VTX A8 80 (80 Hz) preset is used only when subwoofers are available and when the highest A-weighted sound pressure level (SPL) is required. When multiple A8 arrays are used (i.e. main and side arrays), all VTX A8 arrays should be operated in the same LF mode for headroom consistency.

Example 1: A8 80 | SUB: 80

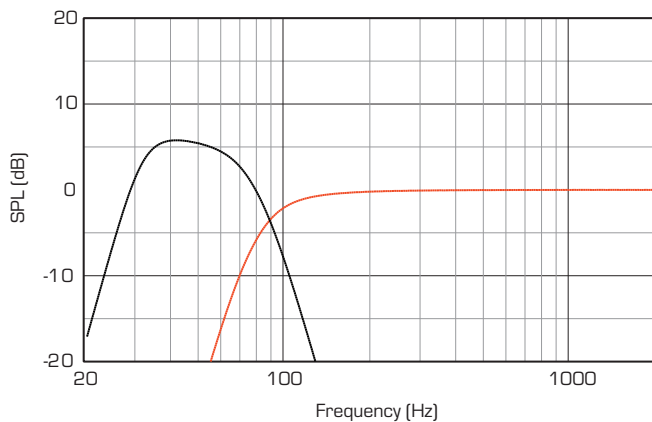

Example 2: A8 FR | SUB: 60 or 80

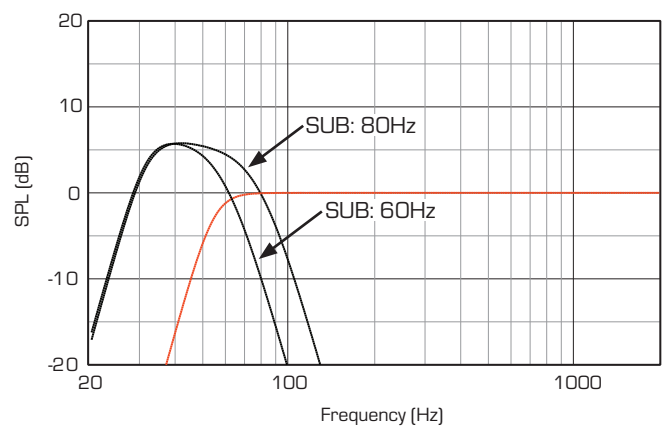

11.2 TIME ALIGNMENT

The VTX A8 presets provide proper system summation with companion VTX subwoofers (all models) in physically coupled configurations (stacked or suspended), and when used with corresponding subwoofer presets. This pre-alignment is done at the factory, allowing any VTX subwoofer to be used with other VTX products without needing specific subwoofer presets for each system and configuration.

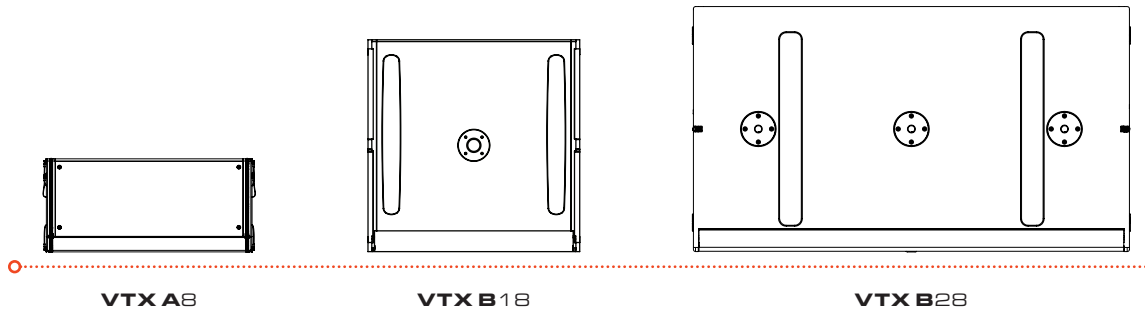

Additional time alignment delay should be added, as necessary, to account for physical path length differences between suspended A8 arrays and ground-stacked VTX subwoofers. If no acoustic measurement system is available, delay values can be calculated based on the geometric path difference between a reference point (i.e. FOH position) and each system. This is an effective method, since all VTX presets include a factory pre-delay to correctly align all components. When the latency of a system is unknown, this method is not effective and should not be used. This can occur when the signal paths of different parts of the system vary in latency.

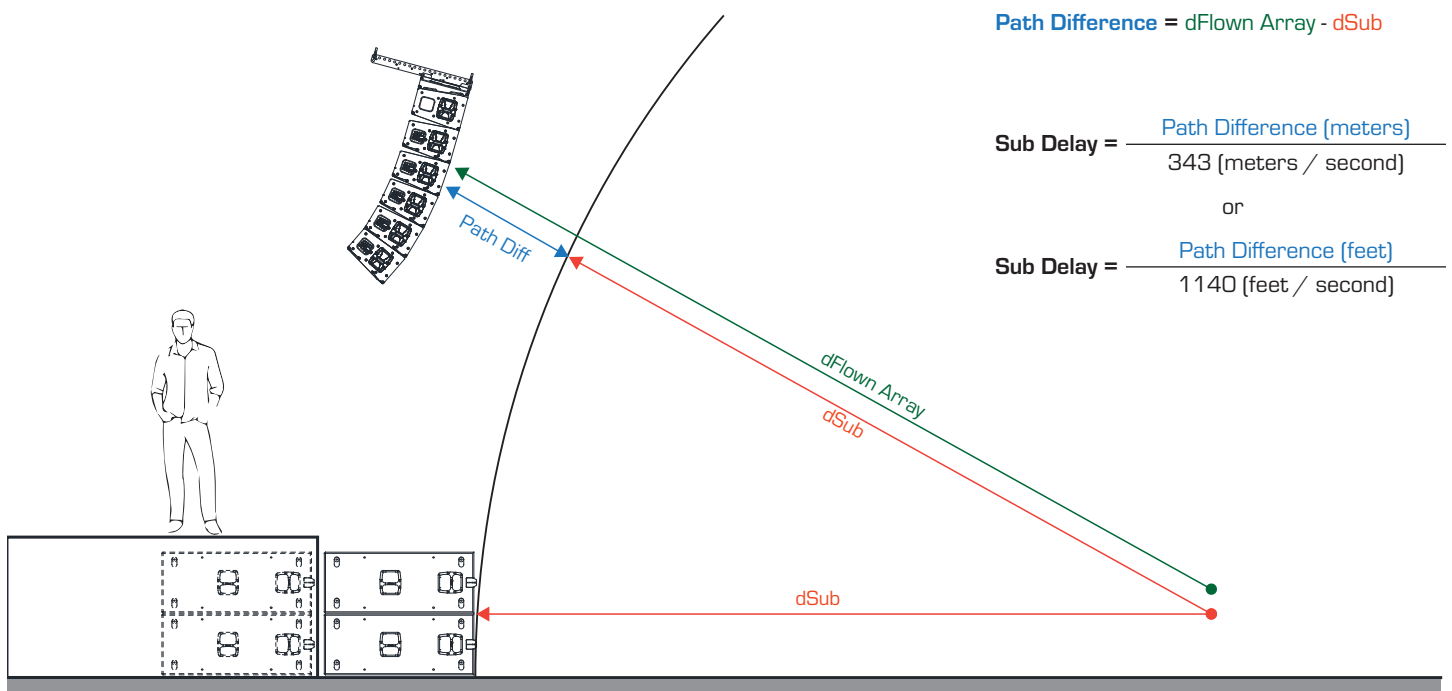

12 - CONFIGURATION EXAMPLES

12.1 SMALL A8 SYSTEM

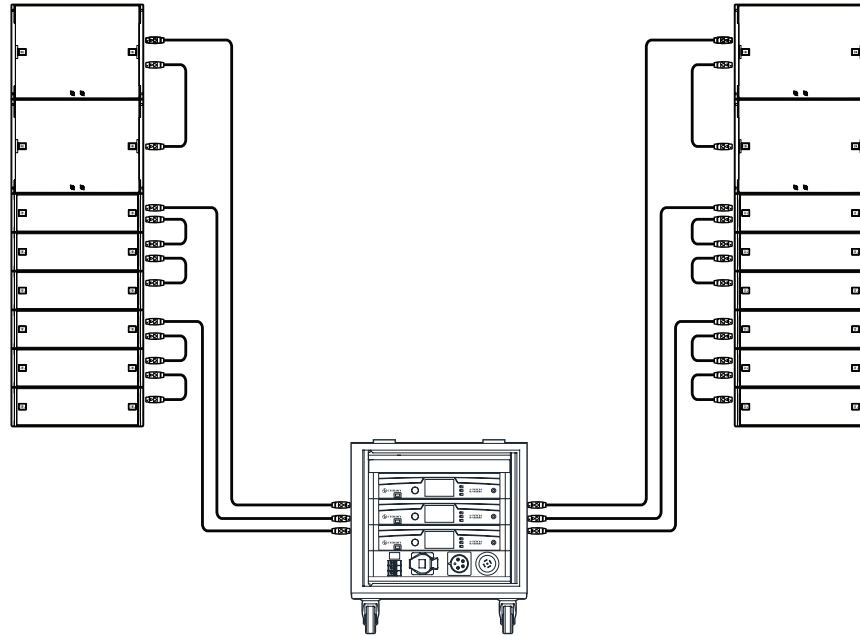

12.2 MEDIUM A8 SYSTEM

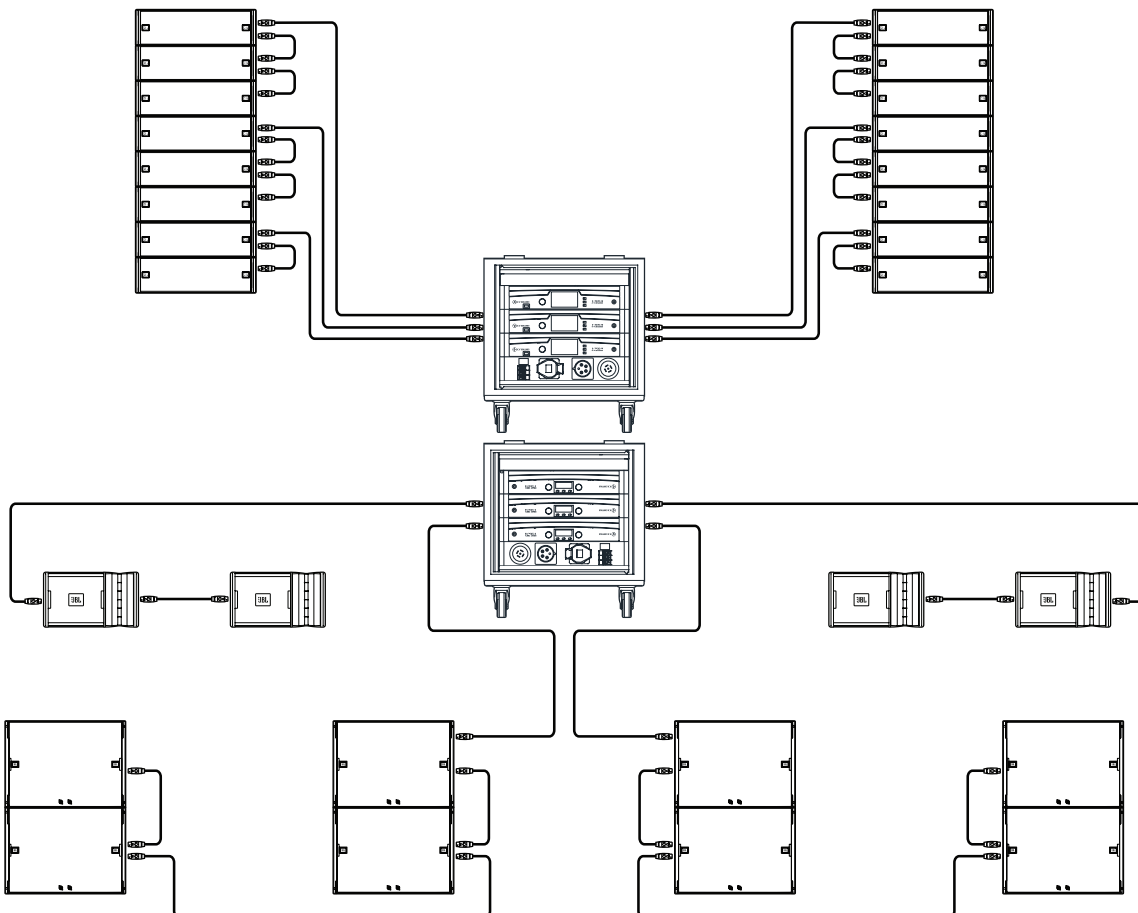

12.3 LARGE A8 SYSTEM

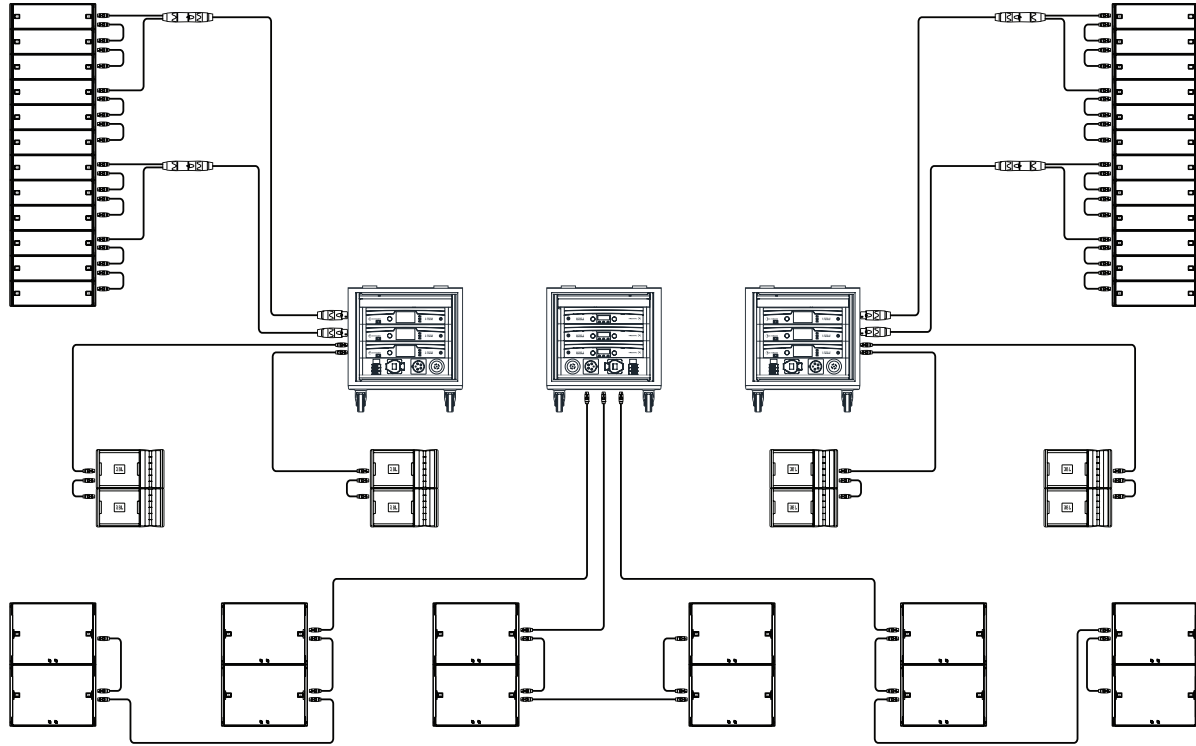

12.4 LARGE A8 AND A12 SYSTEM

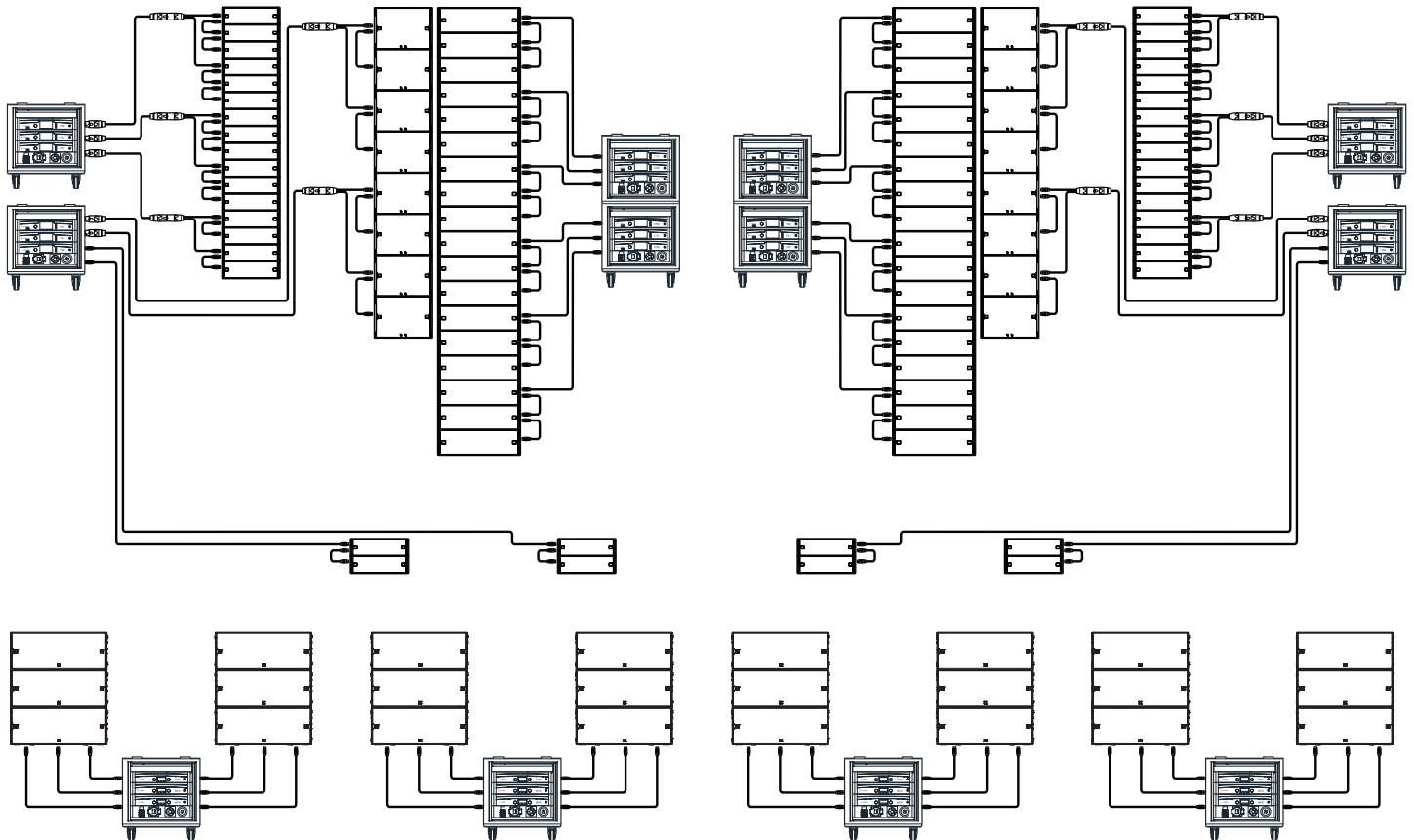

13 - FREQUENCY RESPONSE

The frequency response of a line array is determined by many factors, including the array size (number of cabinets), array curvature (cabinet-to-cabinet angles) and the listening distance. JBL factory presets are designed to create a well-balanced tonal starting point for a given set of array conditions. For example, the standard VTX A8 array presets are designed to work optimally with arrays of 8-12 cabinets and equal impact spacing for a flat listening plane. An array with these parameters generates a flat HF frequency response with a gradual increase in LF energy. The frequency at which the response starts rising depends on the array parameters mentioned above. A relatively short array will start rising lower in frequency, while a longer array starts rising at a higher frequency. Below are frequency response examples of A8 arrays using the standard VTX A8 presets and no additional equalization/correction (flat).

Example 1 : A8 Frequency response vs number of cabinets

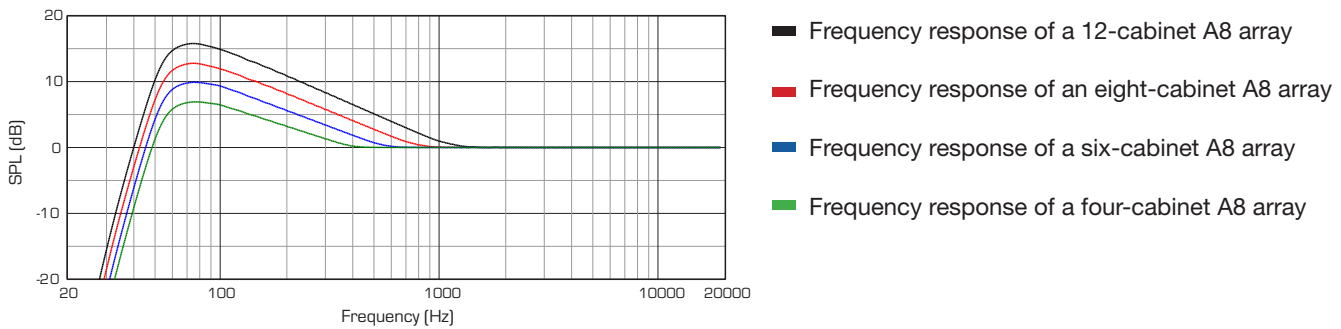

Example 2: Standard preset vs 80 Hz preset

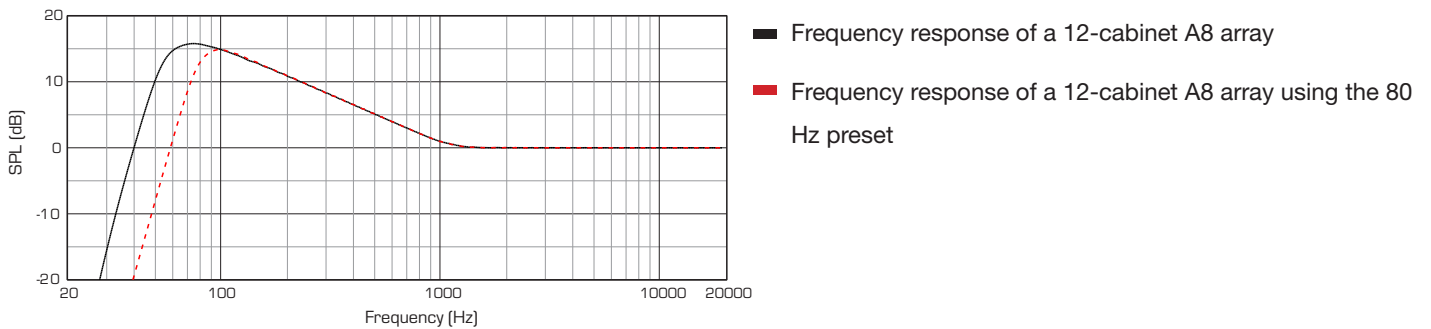

Since the factory preset cannot account for all variables and array configurations, user adjustment of certain DSP parameters is necessary to achieve the desired tonal balance for a given array and application. The LF response of any VTX line array system can be easily adjusted using the Array Size Compensation Filter in the JBL Line Array Control Panel. The Array Size Compensation Filter was specifically designed to compensate for LF/MF buildup with a single, adjustable parameter. Lowering the gain value of this filter shifts lower the frequency at which LF response starts rising— similar to the behavior when array length is shortened.

14 - LINE ARRAY CONTROL PANEL

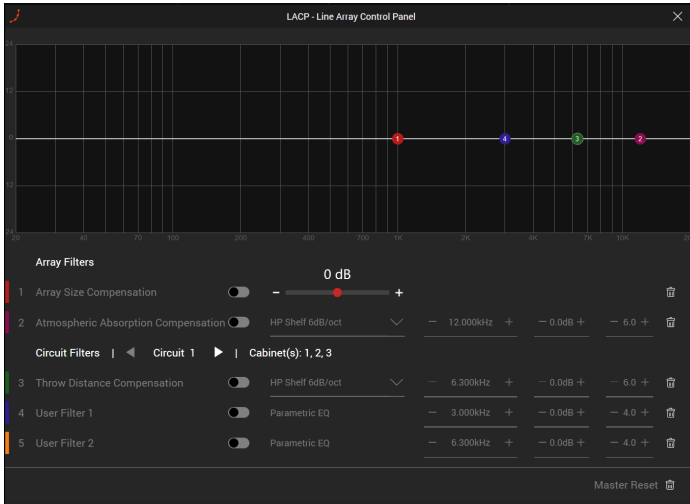

The JBL Line Array Control Panel (LACP) was designed to tailor the tonal balance of a line array using the five included, adjustable, DSP filters. Each filter serves a specific, intended purpose and accelerates the tuning process. Two of these filters are global adjustments grouped across the entire array, and three filters are for circuit-specific adjustments. LACP parameters can be modeled using the Line Array Calculator and then applied to amplifiers in real time using Performance Manager control software.

14.1 ACCESSING LACP

LACP filters can be modeled in the Line Array Calculator 3 and then imported into Performance Manager for deployment to actual devices. To access LACP within the Line Array Calculator, first use LAC's grouping features to create circuit groups. The groups should represent the actual array amplification and wiring to enable realistic and accurate DSP adjustments. Click on the LACP button next to any circuit group to edit it.

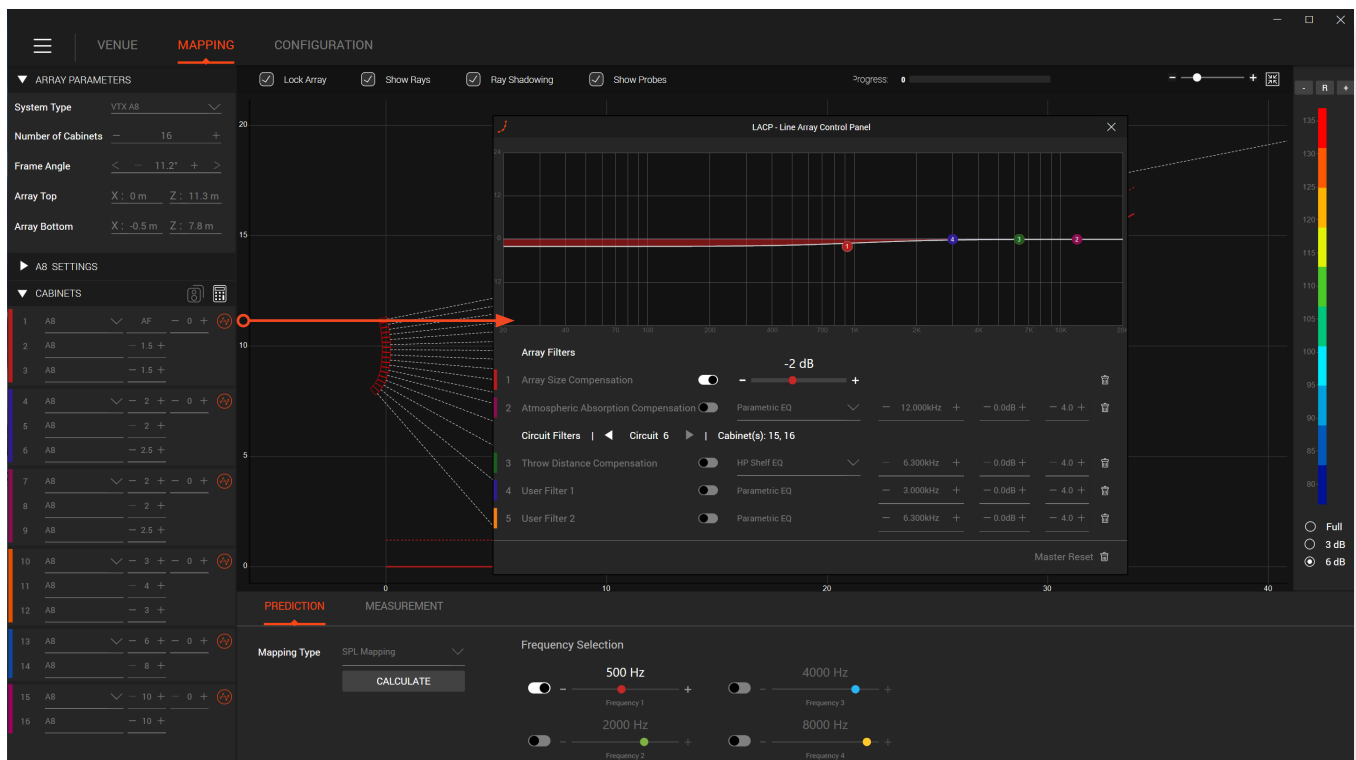

14.2 FILTER 1 - ARRAY SIZE COMPENSATION

Filter 1 is used to correct for LF/MF buildup when the array size or shape differs from that for which the factory preset was designed. LF adjustments should be applied to all cabinets within the array; therefore, filter 1 is automatically applied globally. Filter 1 is a continuously variable LF shelving filter, and its parameters (corner frequency and slope) are adjusted based on the applied gain value. Array buildup is different for each configuration, and Filter 1 is optimized to correct for this effect using only one parameter (Gain).

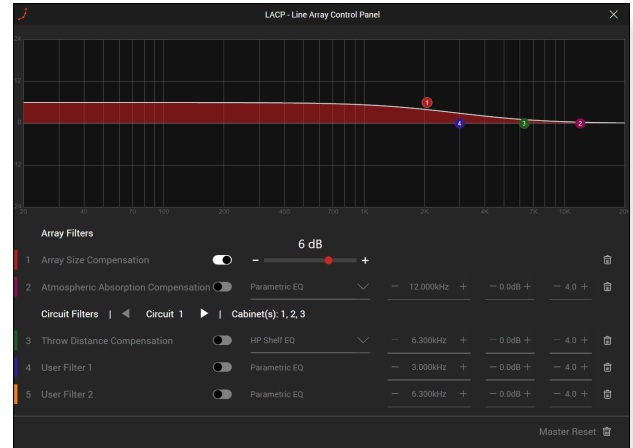
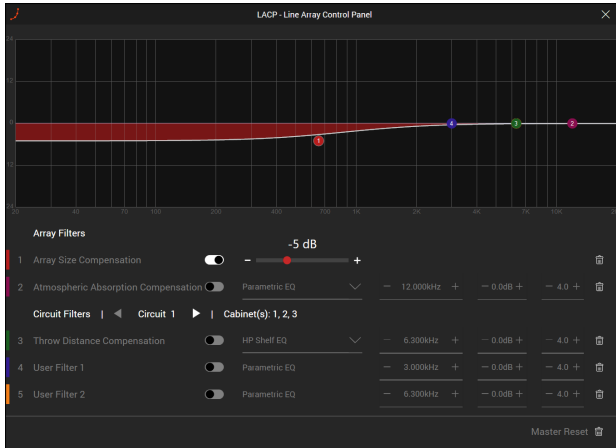

14.3 FILTER 2 - ATMOSPHERIC ABSORPTION COMPENSATION

Filter 2 is used to compensate for large variations in temperature and humidity, which can have an impact on overall HF energy. Filter 2 is applied globally and can be used to quickly brighten or darken an array. This filter can also be used for artistic purposes to adjust overall system tonal balance. The result of atmospheric changes can be modeled in LAC by adjusting the temperature and humidity controls.

14.4 FILTER 3 - HF THROW DISTANCE COMPENSATION

Filter 3 is typically used to correct for distance offsets between different sections of an array. The Type, Frequency and Q parameters are linked across the entire array, but the Gain parameter is adjustable per circuit group. This filter can be used to reduce HF energy close to an array and increase HF energy to areas further away, where air absorption has a bigger impact.

14.5 FILTERS 4 & 5 - USER PEQ 1 & 2

Filters 4 and 5 are User parametric EQs, which can be applied to individual circuit groups as needed. The Frequency and Q parameters are not linked across circuits and, for this reason, it is recommended that User PEQ 1 & 2 are used only for moderate gain changes of frequencies above 1kHz. In this range, the directivity of the high frequency waveguides is narrow enough that changes done to one circuit group will have minimal effects in other areas of the venue.

14.6 EXAMPLE USING LACP

This example is for an array of 12 VTX A8 cabinets. The standard A8 preset is used with the Array Size Compensation filter set to -3 dB to offset LF buildup and achieve a flatter frequency response. As seen from the illustration below, Array Size Compensation is globally applied to all array circuits. The bottom circuit includes some attenuation from HF Throw Distance Compensation (Filter 3) to correct for proximity differences. Some simple adjustments to the LACP filters will get an A8 system to a very good starting point. The need for further adjustments will be dependent on the room and the specific application.

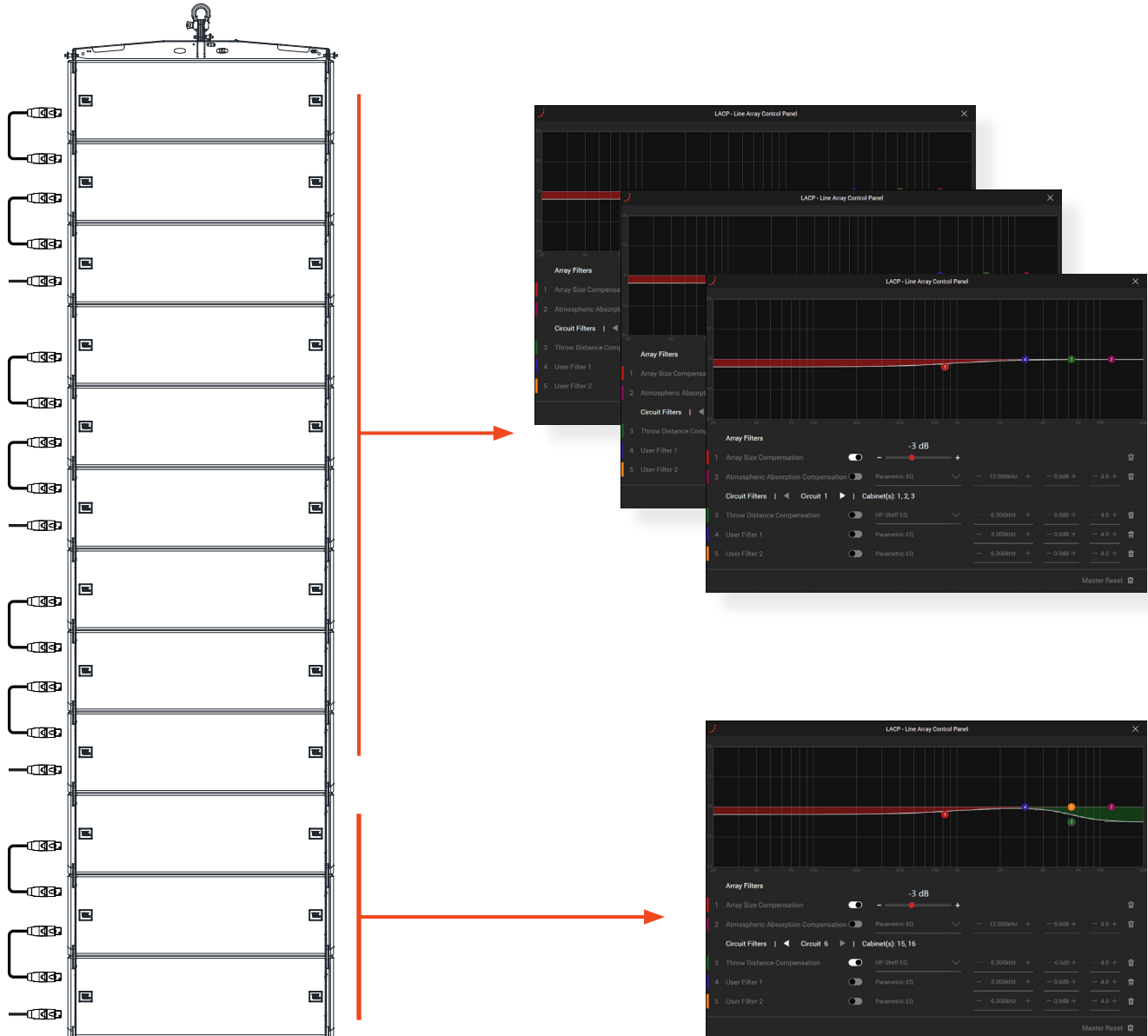

TIP: The LACP parameters used in LAC to predict an array can be easily deployed to an actual array in Performance Manager. For information on how to import LACP parameters into Performance Manager, please refer to the Performance Manager documentation.

15 - TESTING THE VTX A8

Speakers need to be periodically checked and maintained to assure long-term performance and reliability. While the VTX A8 is designed for the utmost reliability, it is important to confirm that the system is operating within specified tolerances to ensure optimal performance for years to come. Below are two methods that can be used to check and verify proper transducer performance in a VTX A8 system.

15.1 USING A DMM (DIGITAL MULTI METER)

This method is best suited for when the speaker system is in the shop. A DCR (DC resistance) test with a multimeter can give a very accurate reading of how many transducers are properly wired together and within their standard operating tolerances. This test is appropriate for individual cabinets and not groups.

With the A8 speaker unconnected to any amplifiers, set a DMM to the resistance (Ω) setting and place the probes across the Pin1+/- and Pin 2+/- leads. Record the values indicated on the DMM for each pair of leads and refer to the chart below to either confirm correct readings or investigate out-of-tolerance DCR readings. Note that a passive network is used between the MF and HF sections, so any major deviations from the values listed below should be further examined by removing the input panel and testing the individual components.

A8 MF/HF Section (Pin 2)		
	DCR	Tolerance
All drivers functioning	6.5 Ω	+/- 0.2 Ω
Any driver shorted	0.2 Ω	-

A8 LF Section (Pin 1)		
	DCR	Tolerance
All woofers functioning	5.2 Ω	+/- 0.2 Ω
One woofer open	10.1 Ω	+/- 0.2 Ω
Two woofers open	OL	-
Any driver shorted	0.2 Ω	-

B18		
	DCR	Tolerance
B18 functioning	4.5 Ω	+/- 0.2 Ω
Driver shorted	0.2 Ω	-

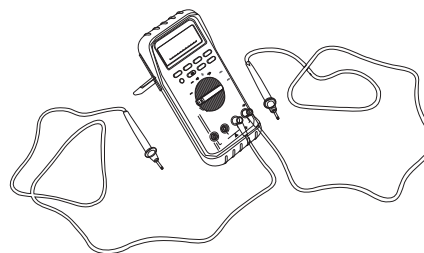
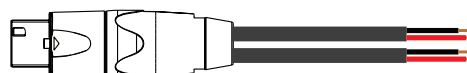
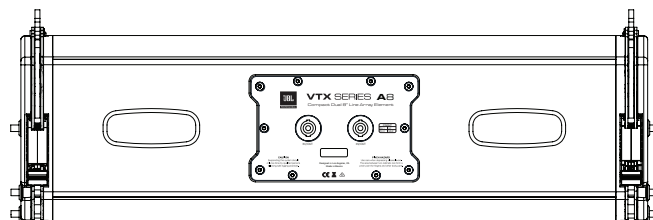

NOTES:

- The DCR values listed above assume room temperature transducers. If measurements are taken right after use, when the transducers are warm, the values will vary. For best results, test the speakers cold.
- The DCR value of a transducer gives an accurate representation of its electrical state, but mechanical defects are not characterized by this test. Refer to the **VTX A8 Service Manual** for instructions on performing a rub-and-buzz test with a sine wave generator.

15.2 TESTING INDIVIDUAL COMPONENTS

Testing the individual sections of an A8 enclosure requires removing the input panel and bypassing the passive network. Remove the (10) T15 screws holding the panel, then slide the input panel out of the A8 enclosure. Once the panel has been removed, disconnect the Molex™ connector from the board as illustrated below.

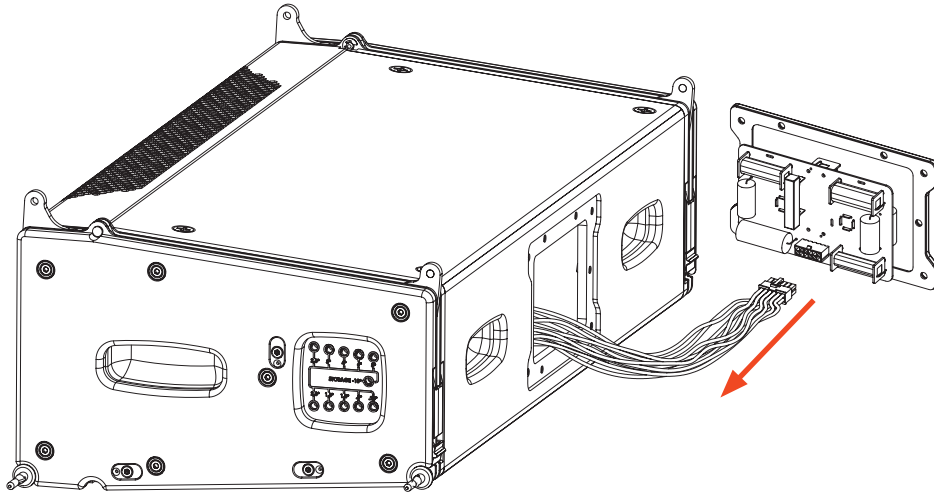

The Molex™ connector has 12 pins that can be used with a DMM to test the individual sections of the A8 speaker. The pin assignments of the Molex connector are listed below. Note that the locking tab of the connector should be oriented face up. Insert the DMM test leads into the pins to take the measurements. The DCR values of each section should be within the given tolerances of the values listed below. Since each pair of MF transducers is wired in series, if an open (overload) is measured, one or both of the transducers might be defective.

Pins	Section	DCR	Tolerance
Pins 1 & 2	LF Right	10.1 Ω	+/- 0.2 Ω
Pins 7 & 8	LF Left	10.1 Ω	+/- 0.2 Ω
Pins 3 & 4	MF Right	12 Ω	+/- 0.2 Ω
Pins 9 & 10	MF Left	12 Ω	+/- 0.2 Ω
Pins 5 & 11	HF 1	20 Ω	+/- 0.2 Ω
Pins 6 & 12	HF 2	20 Ω	+/- 0.2 Ω

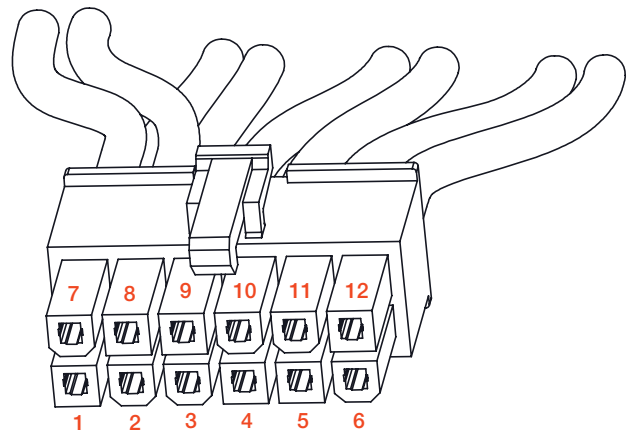

TOOLS REQUIRED: A size 15 TORX screwdriver is required to remove the screws holding the input panel on the A8 enclosure. A high-quality digital multimeter is required for measuring the transducers.

15.3 USING PERFORMANCE MANAGER

When in the field, the **Test System Mode** in the Performance Manager software can be used to test an A8 system. This test method is quick and especially useful for determining whether all speaker cables, including cabinet-to-cabinet NL jumpers, are properly functioning.

To perform the test, Performance Manager uses the I-Tech HD's built-in noise generator in conjunction with the amplifier's current draw and voltage sensing capabilities to generate a nominal load impedance reading for each amplifier output channel. Since broadband pink noise is used as the test stimulus, the returned value is considered to be an impedance value, and it will differ from the resistance values given earlier in this document (which are taken using DC voltage as the stimulus).

STEPS:

- 1 Make sure Performance Manager is online and connected to the devices.
- 2 Navigate to the Test System Mode and make sure all speakers are muted.
- 3 Switch the Noise Generator to the ON position and change the level to a value between -30 dB and -10 dB. Values lower than -30 dB may be insufficient to trigger a reading.
- 4 Unmute the speaker or a bandpass to start the measurement. The measured value is displayed on the speakers.

15.4 PERFORMANCE MANAGER READINGS

Below are the expected impedance values for circuits of A8 cabinets. The measurements below were taken at room temperature with a cable length of 25 m (82 ft). Acceptable tolerance is +/- 0.5 Ω.

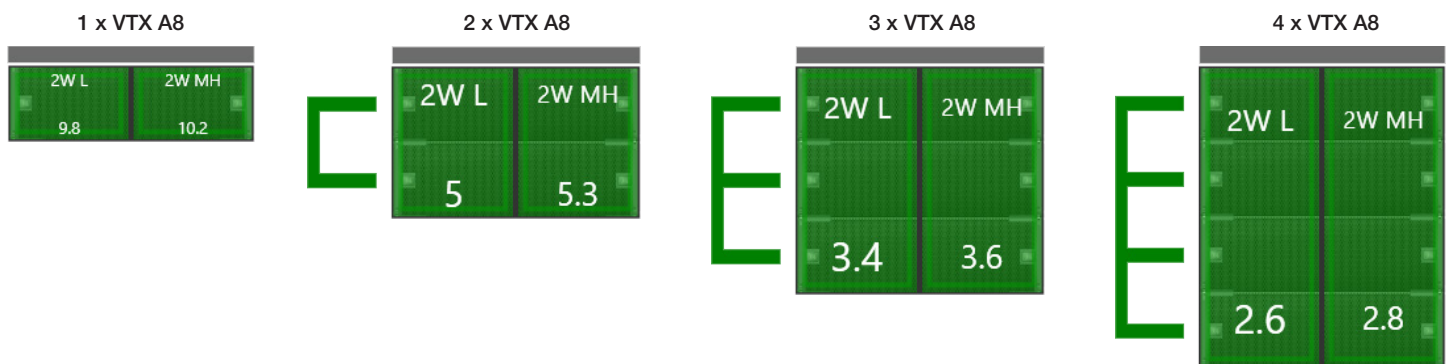

Variations in temperature, cable length, wire gauge and usage can make the measurements recorded by Performance Manager more susceptible to drift. However, variations in conditions like temperature are common across all similar circuits of a system. More important than the individual component values is consistency across similar circuits. For example, all three-cabinet circuits for an array should measure similarly. If one is off by several ohms, there is likely something wrong with that specific circuit.

16 - SPECIFICATIONS

SYSTEM

Frequency Range (-10 dB): 49 Hz - 19 kHz (Preset: VTX A8)

Coverage Pattern (-6 dB)

Horizontal: 110 degrees nominal (300 Hz-18 kHz)
Vertical: Varies with array size and configuration

System Input Power Rating¹

LF : 600 W Continuous (IEC/100 hour)
MF/HF : 390 W Continuous (IEC/100 hour)

Maximum Peak Output²: 139 dB (Preset: VTX A8)

System Amplification: Crown I-Tech HD (all models)
 Crown I-Tech 4x3500HD

Required Amplifier Channels: Two-Channels, Bi-Amp (LF|MHF)

Number of Cabinets per Circuit: (3) VTX A8

System Impedance

LF : 8 ohms
MF/HF : 8 ohms

TRANSDUCERS

Low Frequency : (2) JBL 258J, 8 in diameter, dual 2.5 in diameter voice coil, Neodymium Differential Drive[®]

Mid Frequency : (4) JBL 2163H, 3 in diameter, 1.5 in diameter voice coil, Neodymium magnet

High Frequency : (2) JBL 2423K, 2 in diameter annular diaphragm, 2 in diameter voice coil, Neodymium compression drivers

ENCLOSURE

Construction : 9 mm 9-ply Finnish birch plywood, black DuraFlex[™] finish, four integral recessed handholds

IP Rating³ : IP55 (IEC 60529)

Suspension : High-grade steel with anti-corrosion coating, captive suspension plates, quick release pins, auto-locking mechanism for setting angles

Inter-enclosure Angle : 0.25, 0.5, 1, 1.5, 2, 2.5, 3, 4, 6, 8, 10

Grill : Powder-coated 1.5mm (16-gauge) hex-perforated steel with acoustically transparent black cloth backing

Connectors

Type : Neutrik[®] speakON[®] NL4 (2)
Pin Assignments : Pins 1 ± (LF), Pins 2 ± (MF/HF)

Dimensions (H x W x D) : 227 mm x 761 mm x 375 mm
 8.9 in x 29.9 in x 14.7 in

Net Weight : 29.5 kg (65 lbs)

Footnotes:

1: IEC Standard: IEC shaped noise with 6 dB crest factor based on nominal impedance and a duration of 100 hours. Continuous is defined as 2x RMS

2: Peak, unweighted SPL, measured under full-space conditions at 1 meter using broadband pink noise with a 12 dB crest factor and specified preset

3: Front face at 0 degrees or greater down angle to allow the cabinet to drain water. Suspension components fully weather rated for indoor or covered outdoor conditions where humidity is nominally under 50% and not local to bodies of corrosive materials. Unused speakON connectors must be sealed using silicone to protect against water and moisture.

JBL continually engages in research related to product improvement. Some materials, production methods and design refinements are introduced into existing products without notice as a routine expression of that philosophy. For this reason, any current JBL product may differ in some respect from its published description, but will always equal or exceed the original design specifications unless otherwise stated.

17 - ACOUSTIC MEASUREMENTS

FREQUENCY RESPONSE

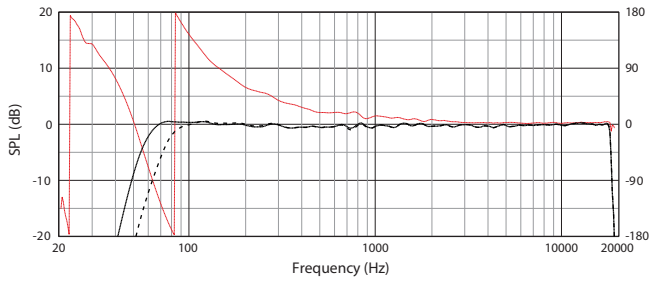

— VTX A8 FL - - - VTX A8 FL 80 — VTX A8 Phase

BEAMWIDTH

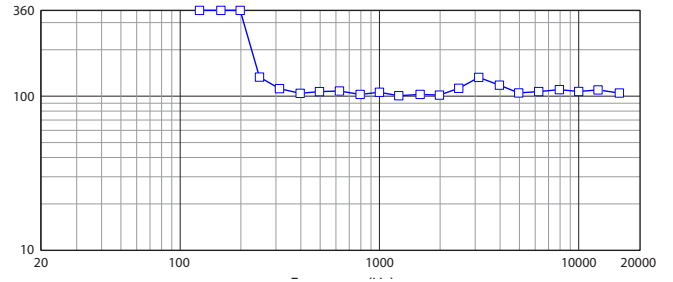

— Horizontal Beamwidth (-6 dB)

18 - DIMENSIONS

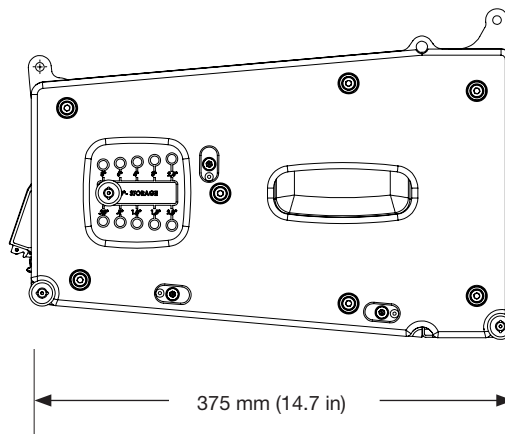
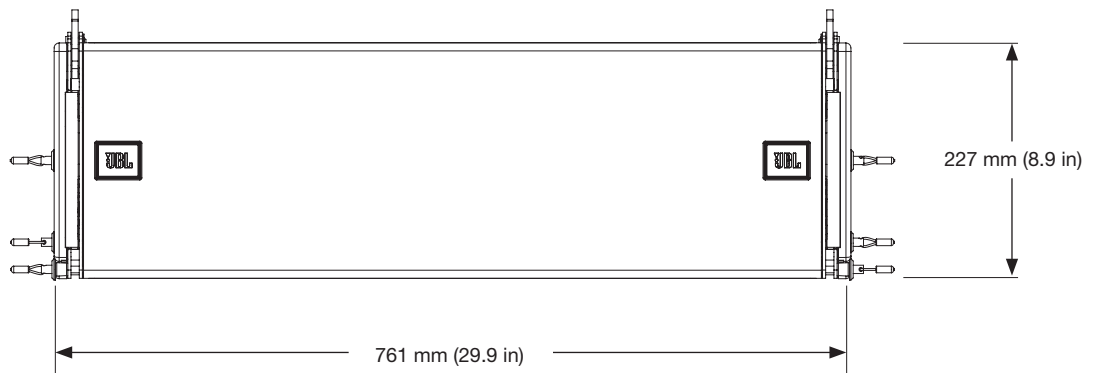

19 - CONTACT INFORMATION

UNITED STATES OF AMERICA

HARMAN Professional Solutions

8500 Balboa Blvd.
Northridge, CA 91329
USA
+1 (844) 776-4899
www.jblpro.com

U.S.A. Technical Support

+1 (844) 776-4899
HProTechSupportUSA@Harman.com
www.jblpro.com

PROFESSIONAL CONTACTS, OUTSIDE THE U.S.A.:

Contact the JBL Professional distributor in your area. A complete list of JBL Professional international distributors is provided at our U.S.A. website: www.jblpro.com

HARMAN Professional EMEA

Westside
London Road
Hemel Hempstead
HP3 9TD
United Kingdom
www.pro.harman.com
www.jblpro.com/support

HARMAN Professional APAC

108 Pasir Panjang Road
#02-08 Golden Agri Plaza
Singapore 118535
+65 6870-5000
www.pro.harman.com
www.jblpro.com/support

HARMAN Professional China

20F, China Merchants Port Plaza, #1
Gongye 3rd Road, Shekou, Nanshan
Dist.
Shenzhen, 518067, China
400 166 7806
www.harman.com/China
www.jblpro.com/support

China In-Country Support

ChinaPRO.Service@harman.com

HARMAN Professional India

Prestige Technology Park
Jupiter 2A Block, 4th Floor
Marathahalli Ring Road
Bangalore 560103, India
+1 (800) 208-8880
www.harman.com/India
www.jblpro.com/support

HARMAN Professional Brazil

Br386, Km435 92480-000
Nova Santa Rita Rs
Brazil
+55 51 34794000
www.harman.com/Brasil
www.jblaudio.com.br
www.jblpro.com/support

India In-Country Support

www.harman.com/india/india-service-center

Brazil In-Country Support

tecnica@harman.com

